

Model 2812

50 Hz 60 Hz

Submersible Grinder Pump

Two Stage

Features:

- Hardened 440 stainless steel (56-60 Rockwell) shredding ring and grinding impeller
- Cast iron ASTM A48 Class 30
- Semi-open impeller prevents clogging
- Ductile iron impeller for superior quality and long life
- Both ends of the pump are protected by a single silicon carbide mechanical shaft seal with a back up lip seal
- Thermal overload protection (single phase) mounted directly on the windings to protect against overheating
- Oil-filled motor for better cooling
- The cord seal is epoxy-potted for superior moisture resistance and anti-wicking
- 1-1/4" NPT discharge
- 10 m (33') cord (50 Hz) / 9 m (30') cord (60 Hz)

Applications:

- Low pressure sewer systems
- High head sewage systems

100% factory tested



Trusted. Tested. Tough.®



ZT0284_Ec
0122
Supersedes
0721

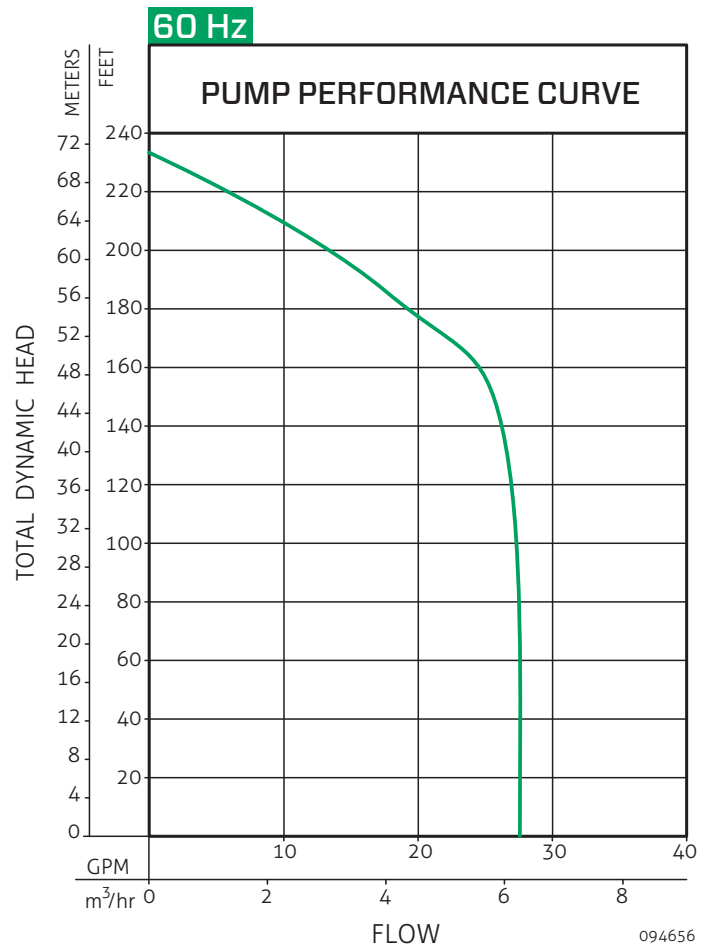
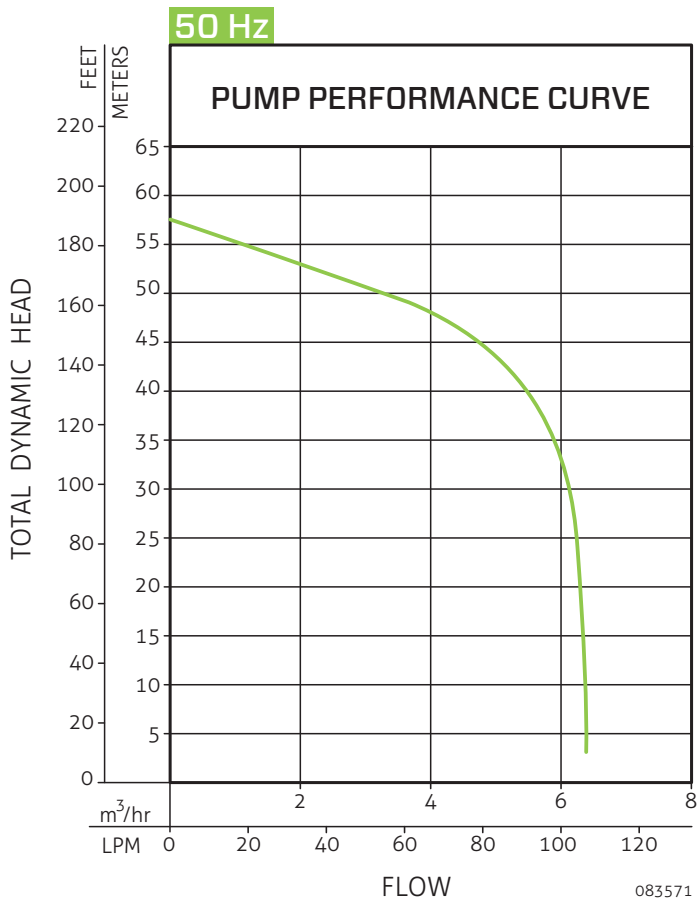

50 Hz

Model	Single Seal	Mode	Volts (V)	Ph Ø	Amps (A)	Motor		Weight	
						kW (p1)	HP	kg	lbs
V2812		Non-Auto	220	1	19.0	4.0	2	62	137
AV2812		Non-Auto	415	3	6.0	3.6	2	62	137

60 Hz

Model	Single Seal	Mode	Volts (V)	Ph Ø	Amps (A)	Motor		Weight	
						HP	kW (p1)	kg	lbs
E2812		Non-Auto	230	1	24.0	2	5.0	62	137

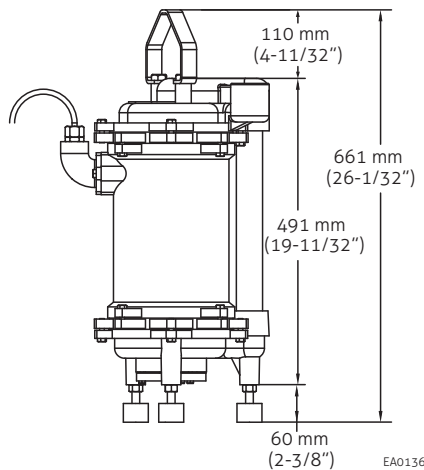
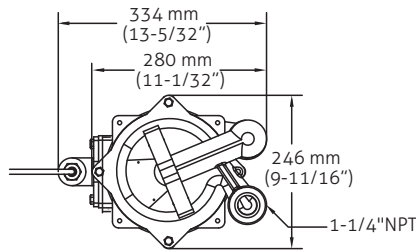

Product information presented here reflects conditions at time of publication. Consult factory regarding discrepancies or inconsistencies.