

Model 2732HF

60 Hz

Submersible Grinder Pump

Features:

- Hardened 440 stainless steel (56-60 Rockwell) shredding ring and grinding impeller
- Cast iron ASTM A48 Class 30
- Semi-open impeller helps prevent clogging
- Ductile iron impeller for superior quality and long life
- Single silicon carbide mechanical seal with secondary lip seal
- Thermal overload protection (single phase) and thermal sensor protection (three phase) mounted directly on the windings to protect against overheating
- Oil-filled motor for better cooling and lubrication
- The cord seal is epoxy-potted for superior moisture resistance and anti-wicking
- 1-1/4" NPT discharge
- 9 m (30') cord

Applications:

- Low pressure sewer systems
- High head sewage systems
- Domestic, commercial, wastewater and sewage

100% factory tested



Trusted. Tested. Tough.®



ZT0246_Ea
1120
Supersedes
0320

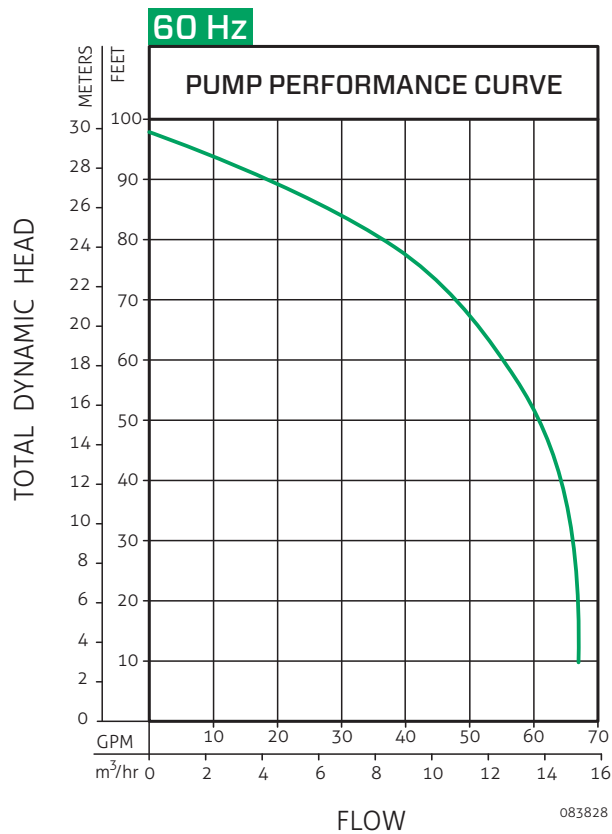

60 Hz

Model	Mode	Volts (V)	Ph Ø	Amps (A)	Motor		Weight	
					HP	kW (p1)	kg	lbs
BL2732HF	Non-Auto	220	1	14	2	----	45	99
K2732HF	Non-Auto	380	3	5.0	2	3.2	42	93

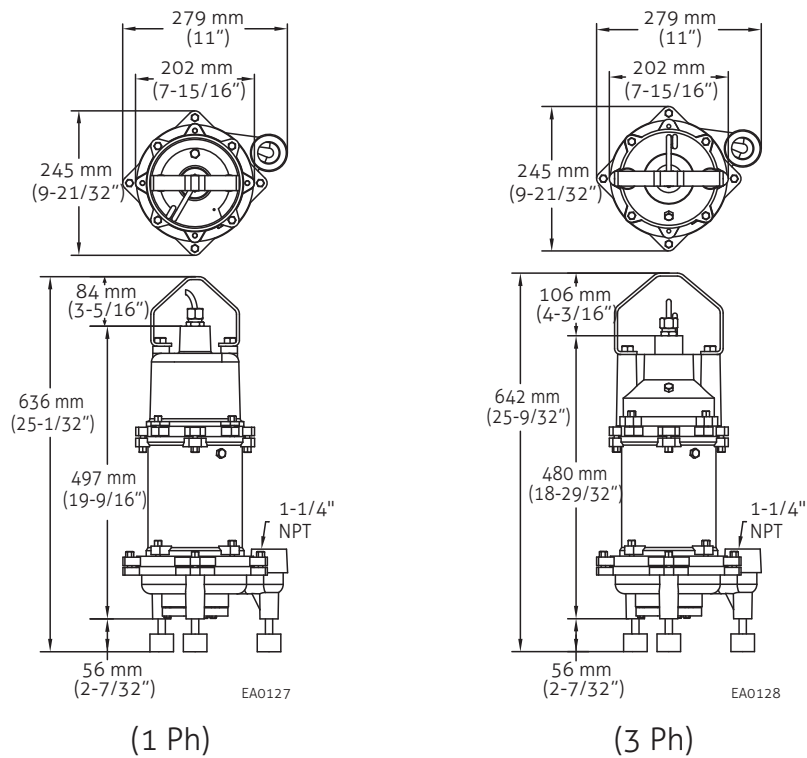

Product information presented here reflects conditions at time of publication.
Consult factory regarding discrepancies or inconsistencies.