

Notice to Installer: Instructions must remain with installation.

ZT0322_ECa

0619

Supersedes

0419

Trusted. Tested. Tough™

Product information presented here reflects conditions at time of publication. Consult factory regarding discrepancies or inconsistencies.



60 Hz









Visit our web site:
www.zoellerpumps.com

INSTALLATION INSTRUCTIONS

2753 / 2755 / 2757 / 2763 / 2765 / 2767

PREINSTALLATION CHECKLIST - ALL INSTALLATIONS

- Inspect your pump.** Occasionally, products are damaged during shipment. If the unit is damaged, contact your dealer before using. **DO NOT** remove the test plugs in the cover nor the motor housing.
- Carefully read the literature** provided to familiarize yourself with specific details regarding installation and use. These materials should be retained for future reference.

  WARNING SEE BELOW FOR LIST OF WARNINGS	SAFETY INSTRUCTIONS
<ol style="list-style-type: none"> To reduce the risk of electrical shock, a properly grounded receptacle or control box must be installed in accordance with the governing codes. Never remove ground pin from plug. Make certain that the receptacle or control box is within reach of the pump's power supply cord. DO NOT USE AN EXTENSION CORD. Extension cords that are too long or too light do not deliver sufficient voltage to the pump motor, and they could present a safety hazard if the insulation were to become damaged or the connection end were to fall into a damp or wet area. Make sure the pump's electrical supply circuit is equipped with fuses or circuit breakers of proper capacity. A separate branch circuit is recommended, sized according to the governing electrical codes for the current shown on the pump name plate. Testing for ground. As a safety measure, each electrical outlet should be checked for ground using a circuit analyzer which will indicate if the power, neutral and ground wires are correctly connected to your outlet. If they are not, call a qualified licensed electrician. FOR YOUR PROTECTION, ALWAYS DISCONNECT PUMP FROM ITS POWER SOURCE BEFORE HANDLING. If pump is wired direct, de-energize the circuit at the control box. DO NOT, UNDER ANY CIRCUMSTANCES, REMOVE THE GROUND PIN. Wear insulated protective shoes and do not stand in water. Pumps equipped with a grounded plug are designed to help protect against electrical shock. A properly grounded receptacle or control box must be installed in accordance with governing codes. Installation and servicing of the pump's electrical circuits and hardware should only be performed by a qualified licensed electrician. Installation and maintenance of this appliance is not intended for persons (including children) with reduced physical, sensory or mental capabilities, or lack of experience or knowledge, unless they have been given supervision or instruction concerning use of the appliance by a person responsible for their safety. Risk of electrical shock. Do not remove power supply cord and strain relief or connect conduit directly to the pump. If the supply cable is damaged, it must be replaced by an authorized Zoeller Representative. Pump may contain oil which becomes pressurized and hot when operating. Allow 2-1/2 hours after disconnecting before attempting service. Pump is not intended for potable water due to possible contamination by oil contained in the pump. Risk of electrical shock. These pumps have not been investigated for use in swimming pools and marine areas. 	<p>TO AVOID SERIOUS OR FATAL PERSONAL INJURY OR MAJOR PROPERTY DAMAGE, READ AND FOLLOW ALL SAFETY INSTRUCTIONS IN THIS MANUAL AND ON THE PUMP.</p> <p>THIS MANUAL IS INTENDED TO ASSIST IN THE INSTALLATION AND OPERATION OF THIS UNIT AND MUST BE KEPT WITH THE PUMP.</p> <p> This is a SAFETY ALERT SYMBOL. When you see this symbol on the pump or in the manual look for one of the following signal words and be alert to the potential for personal injury or property damage.</p> <p> WARNING Warns of hazards that CAN cause serious personal injury, death or major property damage.</p> <p> CAUTION Warns of hazards that CAN cause personal injury or property damage.</p> <p>  Warns of electrical shock hazards that CAN cause serious personal injury, death or major property damage.</p> <p> Identifies any terminal which is intended for connection to an external conductor for protection against electrical shock in case of a fault, or the terminal of a protective earth (ground) electrode.</p> <p> Read operator's manual.</p> <p>THOROUGHLY REVIEW ALL INSTRUCTIONS AND WARNINGS PRIOR TO PERFORMING ANY WORK ON THIS PUMP. MAINTAIN ALL SAFETY DECALS.</p>
<p style="text-align: center;">REFER TO WARRANTY ON PAGE 2.</p>	

DO NOT USE FOR PUMPING OILS, GASOLINE OR ANY PETROLEUM BY-PRODUCTS.

CAUTION

SEE BELOW FOR LIST OF CAUTIONS

1. Check to be sure your power source is capable of handling the voltage requirements of the motor, as indicated on the pump name plate.
2. The installation of variable level float switches is the responsibility of the installing party, and care should be taken that the tethered float switch will not hang up on the pump apparatus or pit peculiarities and is secured so that the pump will shut off. It is recommended to use rigid piping and fittings and the pit be 45 cm (18") or larger in diameter.
3. Vent hole. It is necessary that all submersible sump, effluent and sewage pumps capable of handling various sizes of solid waste be of the bottom intake design to reduce clogging and seal failures. If a check valve is incorporated in the installation, a 5 mm (3/16") vent hole must be drilled in the discharge pipe below the check valve and pit cover to purge the unit of trapped air. Vent hole should be checked periodically for clogging. The vent hole on a High Head application may cause too much turbulence. You may not want to drill one. If you choose not to drill a vent hole, be sure the pump case and impeller is covered with liquid before connecting the pipe to the check valve. NOTE: THE HOLE MUST BE BELOW THE BASIN COVER AND CLEANED PERIODICALLY. Water stream will be visible when pump is operating.
4. Pump should be checked frequently for debris and/or build up which may interfere with the float "on" or "off" position. Repair and service should be performed by an authorized Zoeller Company Representative only.
5. Do not operate a pump in an application where the Total Dynamic Head is less than the minimum Total Dynamic Head listed on the Pump Performance Curves.
6. For health reasons, do not unplug, turn off, or disable pump and use pump tank system as a way to fill up a sink or laundry tray, etc.

LIMITED WARRANTY

Manufacturer warrants, to the purchaser and subsequent owner during the warranty period, every new product to be free from defects in material and workmanship under normal use and service, when properly used and maintained, for a period of one year from date of purchase by the end user, or 18 months from date of original manufacture of the product, whichever comes first. Parts that fail within the warranty period, one year from date of purchase by the end user, or 18 months from the date of original manufacture of the product, whichever comes first, that inspections determine to be defective in material or workmanship, will be repaired, replaced or remanufactured at Manufacturer's option, provided however, that by so doing we will not be obligated to replace an entire assembly, the entire mechanism or the complete unit. No allowance will be made for shipping charges, damages, labor or other charges that may occur due to product failure, repair or replacement.

This warranty does not apply to and there shall be no warranty for any material or product that has been disassembled without prior approval of Manufacturer, subjected to misuse, misapplication, neglect, alteration, accident or uncontrolled act of nature; that has not been installed, operated or maintained in accordance with Manufacturer's installation instructions; that has been exposed to outside substances including but not limited to the following: sand, gravel, cement, mud,

tar, hydrocarbons, hydrocarbon derivatives (oil, gasoline, solvents, etc.), or other abrasive or corrosive substances, wash towels or any other abusive entity, etc. in all pumping applications. The warranty set out in the paragraph above is in lieu of all other warranties expressed or implied; and we do not authorize any representative or other person to assume for us any other liability in connection with our products. Contact authorized distributors to obtain any needed repair or replacement of part(s) or additional information pertaining to our warranty.

MANUFACTURER EXPRESSLY DISCLAIMS LIABILITY FOR SPECIAL, CONSEQUENTIAL OR INCIDENTAL DAMAGES OR BREACH OF EXPRESSED OR IMPLIED WARRANTY; AND ANY IMPLIED WARRANTY OF FITNESS FOR A PARTICULAR PURPOSE AND OF MERCHANTABILITY SHALL BE LIMITED TO THE DURATION OF THE EXPRESSED WARRANTY.

Some jurisdictions do not allow limitations on the duration of an implied warranty, so the above limitation may not apply to you. Some jurisdictions do not allow the exclusion or limitation of incidental or consequential damages, so the above limitation or exclusion may not apply to you.

This warranty gives you specific legal rights and you may also have other rights which vary from jurisdiction to jurisdiction.

In those instances where damages are incurred as a result of an alleged pump failure, the Homeowner must retain possession of the pump for investigation purposes.

EASY DO'S & DON'T'S FOR INSTALLING UNIT

1. **DO** read all installation material included with the pump.
2. **DO** inspect unit for any visible damage caused by shipping. Contact dealer if unit appears to be damaged.
3. **DO** remove all debris from the basin. Be sure that the pump will have a hard, level surface beneath it. **DO NOT** install on sand, gravel or dirt.
4. **DO** be sure that the area is large enough to allow proper clearance for the level control switch(es) to operate properly.
5. **DO always disconnect pump from power source before handling.** **DO** always connect to a separately protected and properly grounded circuit. **DO NOT** ever cut, splice or damage power cord (only splice in a watertight junction box). **DO NOT** carry or lift pump by its power cord. **DO NOT** use an extension cord.
6. **DO** install a check valve and a union in the discharge line. **DO NOT** use a discharge pipe smaller than the pump discharge size.
7. **DO NOT** utilize this unit for pumping gasoline or other hazardous liquids.
8. **DO** test pump immediately after installation to be sure that the system is working properly.
9. **DO** review all applicable local and national codes and verify that the installation conforms to each of them.
10. **DO** consult manufacturer for clarifications or questions.
11. **DO** consider a D.C. Backup System is necessary for the prevention of property damages from flooding due to A.C. power disruptions, mechanical or electrical problems or system overloading.
12. **DO** inspect and test system for proper operations at least every 3 months.

General Maintenance

▲ NOTICE Repair and service should be performed by a Zoeller Pump Company Authorized Service Station only.

SAFETY PROCEDURES



▲ WARNING For your protection, always disconnect pump and panel from its power source before handling.



▲ WARNING Never enter the basin until it has been properly vented and tested. Any person entering a basin should be wearing a harness with safety rope extending to the surface so that they can be pulled out in case of asphyxiation. Sewage water gives off methane and hydrogen sulfide gases, both of which can be highly poisonous.

Installation and checking of electrical circuits and hardware should be performed by a qualified electrician.

Pump is never to be lifted by power cord.



▲ WARNING Unit must be cleaned and disinfected, inside the pumping chamber and all exterior surfaces, prior to servicing.

GENERAL SYSTEM INSPECTION

Before the system is placed into operation, it should be inspected by a qualified technician.



▲ WARNING Wiring and grounding must be in accordance with the National Electrical Code and all applicable local codes and ordinances.

LUBRICATION PROCEDURES

No lubrication is required.

If pumps are to be stored for more than six months, refer to short-term storage procedure in the Operation section.

PREVENTIVE MAINTENANCE

Preventive maintenance is recommended to ensure a long service life from the product. Provided is a suggested maintenance schedule.

Every six months:

- Inspect and test system for proper operation.
- Check for proper and unobstructed float operation.
- Listen for proper check valve operation.

Every 5 years or 10,000 hours of operation:

- Remove pump, inspect and service using a Zoeller rebuild kit.
- Flush and clean basin.

DOUBLE SEAL PUMPS

Double seal pumps offer extra protection when these pumps are supplied with optional moisture sensors, check the control panel's seal failure light for a warning. Whenever the seal leak light is activated, it's indicating that moisture is present, and the pump should be removed and serviced in order to avoid damage to the motor.

SERVICE CHECKLIST



▲ WARNING ELECTRICAL PRECAUTIONS- Before servicing a pump, always shut off the main power breaker and then unplug the pump. "Make sure you are wearing insulated protective sole shoes and not standing in water." Under flooded conditions, contact your local electric company or a qualified licensed electrician for disconnecting electrical service to the pump prior to removal.

▲ WARNING Submersible pumps contain oils which become pressurized and hot under operating conditions. **Allow 2-1/2 hours after disconnecting before attempting service.**

CONDITION	COMMON CAUSES
A. Pump will not start or run.	Check fuse, low voltage, overload open, open or incorrect wiring, open switch, impeller or seal bound mechanically, motor or wiring shorted. Float assembly held down. Switch damaged or out of adjustment.
B. Motor overheats and trips overload or blows fuse.	Incorrect voltage, negative head (discharge open lower than normal) impeller or seal bound mechanically, motor shorted.
C. Pump starts and stops too often.	Float switch tether length too short, check valve stuck open, or none installed in long distance line, overload open, bidding, sump pit too small.
D. Pump will not shut off.	Debris under float assembly, float or float rod bound by pit sides or other, switch defective, damaged or out of adjustment.
E. Pump operates but delivers little or no water.	Check inlet, strainer housing, discharge pipe, and vent holes for obstructions. Discharge head exceeds pump capacity. Low or incorrect voltage. Incoming water containing air or causing air to enter pumping chamber. Incorrect motor rotation. (3 phase pumps only.)
F. Drop in head and/or capacity after a period of use.	Increased pipe friction, clogged line or check valve. Abrasive material and adverse chemicals could possibly deteriorate impeller and pump housing. Check line. Remove base and inspect.

If the above checklist does not reveal the problem, consult the factory. Do not attempt to service or otherwise disassemble pump. Service must be performed by an authorized Zoeller Company representative.

RECOMMENDED INSTALLATION FOR ALL APPLICATIONS

- (1) Electrical wiring and protection must be in accordance with National Electrical Code and any other applicable state and local electrical requirements.
- (2) Install proper Zoeller unichek (combination union and check valve), preferably just above the basin (indoor installations) to allow easy removal of the pump for cleaning or repair. If high head or below cover installation is required use 30-0164 on 1-1/2" (DN40) pipe, 30-0152 on 2" (DN50) pipe and 30-0160 on 3" (DN80) pipe.
- (3) All installations require a basin cover to prevent debris from falling into the basin and to prevent accidental injury.
- (4) When a Unichek is installed, drill a 5 mm (3/16") dia. hole in the discharge pipe even with the top of the pump. **NOTE: THE HOLE MUST ALSO BE BELOW THE BASIN COVER AND CLEANED PERIODICALLY.** (High Head unit see #3 under "Caution" on front page). Water stream will be visible from this hole during pump run periods.
- (5) Securely tape or clamp power cord to discharge pipe, clear of the float mechanism(s).
- (6) Use full-size discharge pipe.
- (7) Basin must be in accordance with applicable codes and specifications.
- (8) Pump must be level and float mechanism(s) clear of sides of basin before starting pump.
- (9) Basin must be clean and free of debris after installation.
- (10) Gate Valve or Ball Valve to be supplied by installer and installed according to any and all codes.
- (11) For nonautomatic pumps, locate float switches as shown in sketches. The best place for the "off" point is above the motor housing and positioned 180° from the inlet. Never put "off" point below discharge on pump.
- (12) Gas tight seals required to contain gases and odors.
- (13) Vent gases and odors to the atmosphere through vent pipe.

INSTALLATION SKETCHES

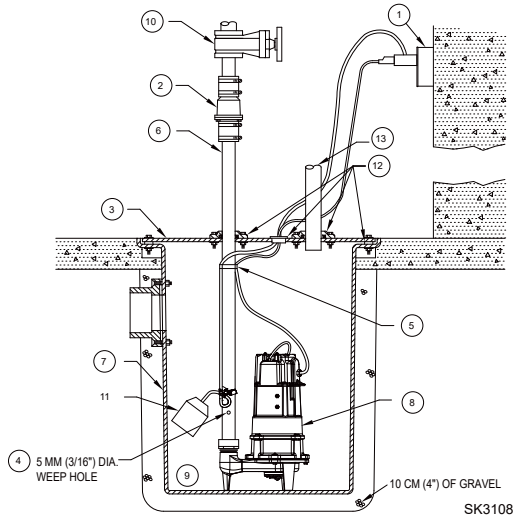

All installations must comply with all applicable electrical and plumbing codes.

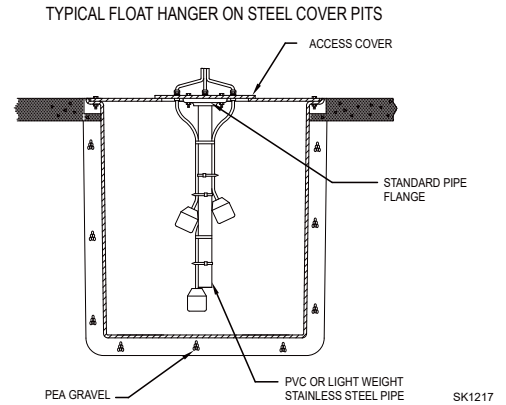

On some installations it may be desirable to install an independent hanger for the level control switches to avoid possible hang ups on the pumps, piping, valves, etc. Float hangers are available from Zoeller Company on Catalog Sheet FM0526 or can be fabricated from standard pipe and fittings.

3 PHASE WIRING DIAGRAM

Model 2753 / 2755 / 2757 / 2763 / 2765 / 2767

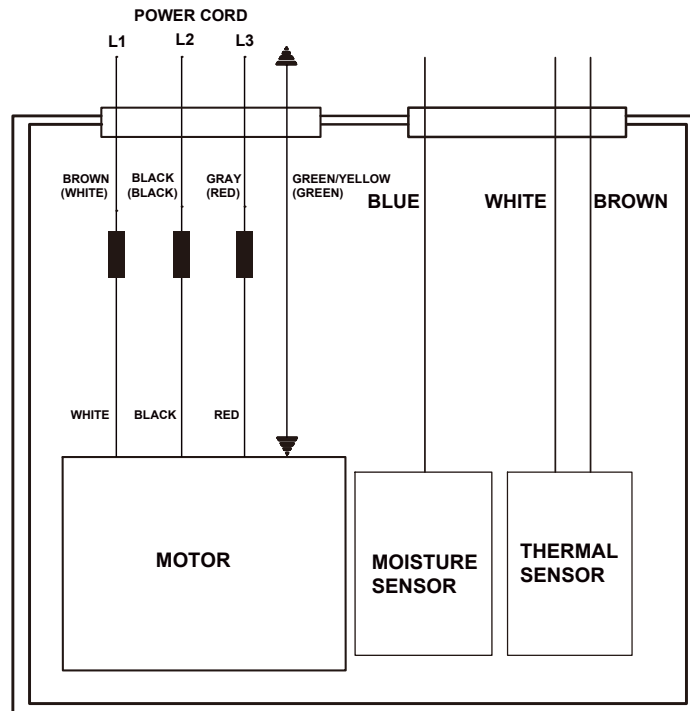

EA0116

安裝前務必詳讀說明書

Trusted. Tested. Tough.™

文件僅供參考
若有任何修改
恕不另行通知



60 Hz









Visit our web site:
zoellerpumps.com

安裝說明書

2753 / 2755 / 2757 / 2763 / 2765 / 2767

安裝前檢查

1. 安裝前請仔細檢查所有零件。產品如果在運送中受損，請儘速聯絡經銷商。
2. 安裝前仔細閱讀所有提供的文件，熟悉安裝細節，並保存資料以供未來參考。

 WARNING 警告	安全守則
<ol style="list-style-type: none">1. 為防範使用者觸電，本公司所有產品皆配有包含接地功能的電線及三插插頭。為確保安全，請勿將插頭的接地插銷拔除。2. 為確保安全請勿使用延長線。加裝延長線容易使水泵馬達接收不到足夠的電壓。更重要的是，若延長線的絕緣遭破壞、或插頭鬆脫掉入水中，將可能造成危險。3. 請確認在供給水泵電源的電路中加裝適當規格的保險絲或斷路器。在此建議依照水泵銘牌上的電流值，並參照國內電工法則來選擇及安裝獨立的斷路器。4. 請在安裝前測試插座的漏電保護功能。為了安全考量，請使用符合國內電工法規的電路測試儀器來檢查插座中的火線、中性線及地線是否配置正確。若發現異常，請聯絡合格的水電技師來為您解決問題。5. 為了保護您的安全，接觸水泵前請先拔除電源。如果水泵使用電線直接連接，需在電控箱內斷電。任何情況下都不允許移除接地插銷。確保人未站在水中，且穿上絕緣鞋。泵配有接地插頭的設計，以幫助防止觸電。必須按國內法規，正確安裝接地的插座或控制箱。6. 僅得由持有證照的合格水電技師來進行水泵安裝、管路搭配及電路配線。7. 若無監督本產品不適合給兒童、心智不健全或經驗不足者使用，前述條件者使用本產品時，監督者應負全部安全責任。8. 為避免觸電，請勿移除電纜線。如果電纜線受損，請聯絡經銷商或本公司核可的服務單位維修。9. 本水泵含冷卻油，在運作狀態下會受壓變熱——斷電後等待2.5小時再進行維修。10. 水泵不可使用於飲用水，冷卻油有可能會污染水質。11. 為防範觸電，本產品勿用於游泳池。	<p>為避免嚴重或致命的人身傷害及重大財產損失，請閱讀並遵守水泵的所有安全操作說明。</p> <p>本說明書在協助安裝和操作本機型時，必須符合水泵的安全操作守則。</p> <p> 這是一個安全警告符號。當你在水泵或說明書中看到此符號，請查詢以下符號，並警惕人身傷害或發生財產損失的可能性。</p> <p> WARNING 警告，表示可能會導致嚴重的人身傷害、死亡或重大財產損失的危險。</p> <p> CAUTION 注意，表示可能會造成人身傷害或財產損失的危險。</p> <p>  電擊危險警告，表示可能會導致嚴重的人身傷害、死亡或重大財產損失的危險。</p> <p> 接地標誌，表示藉由連接外部導體之接地線，在故障時可防止觸電發生。</p> <p> 閱讀操作手冊。</p> <p>使用水泵前，請徹底閱讀本說明書內的說明和警告。並維護所有安全標籤。</p> <p>保固請參閱第06頁。</p>

請勿使用於油類、汽油、石油產品或含任何化學成分的液體。

⚠ CAUTION

注 意

1. 檢查並確認使用的電源符合水泵銘牌上的規格需求。
2. 安裝含自動浮球開關或外接式自動浮球開關的自動型產品時，安裝者有責任確保浮球擺放於正確位置，且不會卡在水泵機組或機坑壁邊，以確保本產品能正常運作。建議使用硬水管做為配管。
3. 排氣孔的目的：
一般沉水型污水泵都是從底部抽水，以防止水泵阻塞和洩漏。空氣會因此容易積在水泵或管路內，造成氣鎖。排氣孔是為了將這些空氣排出。因此，必須在逆止閥與機坑蓋下的管路鑿一排氣孔(直徑約5 mm)，用以排出來自底部入水口的積存空氣。積存的空氣可能源自於水泵運作時的攪動，或於水槽乾涸時進入水泵。排氣孔應定期檢驗，排除阻塞。本產品運轉時看見水從排氣孔流出，為正常現象。
4. 時常檢查是否有雜物卡住浮子。維修請洽本公司認可的維修站。
5. 請勿在總動力揚程低於性能曲線中揚程下限之場合使用。運轉時需保持直立。請勿傾斜水泵。
6. 基於健康理由，不要使用水泵系統來注入水槽或洗衣機的水等。

保固说明

本產品的保固為自購買日起算的一年、或從工廠製造日期起算的1.5年，以先到期者為準。若能證明產品的缺陷是由材料或製造過程造成，本公司將負責維修或更換。本公司保留決定是否維修或更換產品、零件或配件的權利。維修或更換期間買方所產生的費用或損失不在保固範圍內。本公司無法控制的損壞不在保固範圍內。

保固不適用於：

- (1) 未依照說明書安裝、操作或維護所造成的故障或損壞。
- (2) 不當操作、意外或疏忽所造成故障或損壞。
- (3) 加裝不屬於本產品的零、配件。
- (4) 未依照當地法規進行安裝所造成的危害。

(5) 將產品用在非原本設計的用途上所造成的損壞。(例：抽取沙、碎石、水泥、泥巴、瀝青、碳氫化合物及其衍生物、汽油、化學溶劑或其他有腐蝕性的液體、毛巾、女性衛生用品等。)

保固零、配件的退回：在本保固之下任何修理或更換需送回本公司或其他本公司所指定的維修服務點，運費需自付。在任何情況下本公司不負擔其他責任，包含資產或設備的損壞、利潤損失、等.....。

本公司的責任不超過產品的實售價格。

上述為本產品唯一的保固說明，任何人的修改或另做承諾皆為無效。

在因涉嫌產品故障而招致損害的情況下，財產擁有人必須保留該產品以供調查之用。

安裝注意事項

1. 請務必閱讀本裝置之所有安裝資料。
2. 請務必檢查裝置是否在運送中產生可見的損壞。若裝置顯示受損，請洽經銷商。
3. 請務必清除水坑中之雜物。將水泵放置在堅固地面上。切勿將水泵放置在泥沙上。
4. 請務必確認水坑大小足以允許浮子自由活動。
5. 處理前切斷水泵電源。連結到獨立受保護的接地漏電電流斷路器。請勿切斷、拼接或損壞電源線。請勿用電源線拉動或舉起水泵。請勿使用延長線。
6. 請務必在出水管線安裝止回閥和管接頭。切勿使用小於出水口徑尺寸的水管安裝。
7. 切勿使用本裝置抽取汽油或其他危險液體。
8. 請務必在安裝後立即測試水泵，以確認系統正常運作。
9. 請務必詳閱所有適用當地及國家規則，確認安裝符合各項規定。
10. 若有疑問，請務必洽製造商查明。
11. 請務必考慮電池備用系統，以防停電或故障造成的財產損失。
12. 請務必每3個月檢查一次系統是否正常運作。

一般維修

▲ 注意事項 產品維修及維護須由卓勒泵浦公司授權之合格維修站來執行。

安全程序



▲ 警告

為了您的安全考量，在執行作業前請先將泵浦及控制面板上的電源插頭拔除。



▲ 警告

在沒有適當地執行排氣與測試前，請勿進入桶裝地方。任何人進入桶裝地方，須穿著安全護具並繫上可延伸至到地面的安全繩，以防人員窒息時可以被救出。污水會排放出甲烷和硫化氫氣體，二者都是具有高毒性。

電路及其硬體設備安裝及檢查須由合格之電工人員來執行。

請勿用電源線來拉提泵浦。



▲ 警告

維修前，產品之內部泵浦室和所有外部表面都必須進行清理和清潔。

一般系統檢查

在系統被安裝好開始運轉前，須由合格工程技師執行檢驗。



▲ 警告

電路與接地線必須符合國際電氣規範以及適用於所有當地規範及條例。

上油程序

無上油作業需求。

如果泵浦存放超過6個月，請參照短期存放作業的部分來進行

預防性保養

為確保產品的長效運轉壽命，建議作預防性保養。

每6個月：

- 檢查並測試系統是否運轉正常。
- 檢查浮球運作是否正常且無阻礙。
- 傾聽止回閥的運作是否正常。

每5年或10,000 小時運轉：

- 使用卓勒維修套組後，檢查及維護。
- 沖洗及清潔桶子。

雙軸封泵浦：

當雙軸封泵浦連結選配的水氣感應器時，泵浦會提供額外的保護。請檢視控制面板上的軸封失效警告燈。無論何時，只要此軸封洩漏燈亮起時，表示目前有水份存在，需移除泵浦並作保養維護作業，以防止馬達的損壞。

檢查清單



▲ 警告

在維修沉水泵之前，須關閉總電源斷路器，拔除水泵插頭——確保人未站在水中，且穿上絕緣保護底的鞋子。水溢流時，聯絡當地的電力公司，或有執照的合格電氣技師，在移除管之前進行斷電。



▲ 警告

本水泵含冷卻油，在運作狀態下會受壓變熱——斷電後等待2.5 小時再進行維修。

異常狀況	可能原因	補救措施
A. 水泵未開始運作。	低電壓、保險絲燒斷、電路中斷。	由合格電氣技師檢查保險絲和電路。
	葉輪卡住。	聯絡經銷商。
	馬達或電線短路。	
B. 馬達過熱造成跳電或保險絲燒斷。	浮子開關上有雜物。	去除雜物
	電壓錯誤、負揚程(出水口高度低於水泵)、葉輪或軸封卡死、電容器、繼電器或馬達短路。	聯絡經銷商。
C. 水泵啟動停止次數太頻繁。	止回閥阻塞、無止回閥、熱過載保護器啟動或浮子有瑕疵。	聯絡經銷商。
D. 水泵不停止。	浮子下方有雜物。	去除浮子周圍的雜物。
	浮子開關故障。	聯絡經銷商。
E. 水泵運轉正常，但抽不到水或水流量太少。	進水口周圍有雜物。	清理進水口附近區域。
	排放管堵塞。	必要時卸除排放管，沖走雜物。
	電壓太低或不當電壓。	由合格電氣技師檢查家庭管線。
	葉輪受損。	聯絡經銷商。
	馬達運轉不當、電容器瑕疵、入水含空氣或造成空氣進入水機室。	聯絡經銷商。
	水泵氣鎖。	確保排放管中的通氣孔暢通。
F. 揚程或流量使用一般時間後降低。	安裝揚程超過系統設計的揚程。	更換排放管或聯絡經銷商。
	管路或止回閥阻塞。磨蝕性物質及有害的化學物質造成葉輪及水機損壞。	檢查管路、打開並檢查水機。

如果檢查後仍無法排除問題，請與卓勒公司授權的經銷商連絡，切勿自行拆卸水泵。

安裝說明

- ① 電氣配線及保護措施需符合相關電氣規範與當地其他應用慣例之需求。
- ② 請在水槽稍高處安裝適當的活接與止回閥組合組件，以便於拆卸水泵供清潔整理或維修。如果在安裝上高度超出或低於桶蓋時，需於1½" (DN40) 水管上使用30-0164管件，2" (DN50)水管上使用30-0152管件，3" (DN80)水管上使用30-0160的管件。
- ③ 所有安裝需使用水槽蓋板防止雜物掉入水槽，並防止人員意外受傷。
- ④ 請在水泵水管鑽一直徑5 mm 小孔，為避免通氣孔水流影響對浮子的正常運作，通氣孔的位置請避免面向浮子。建議鑽孔位置低於”停止”水位，建議向下45度角可降低水流撞擊桶子產生的噪音。註：該孔需低於水槽蓋板，並需定期清理，水泵運轉時可看見該小孔有水流出。
- ⑤ 用束帶將電源線在出水管上固定牢靠，並使其避開浮子開關機構。
- ⑥ 出水管管徑不可小於水泵出口口徑。
- ⑦ 水槽需符合適用規範及規格。
- ⑧ 啟動水泵前確認水泵水平，且浮子開關機構與水槽邊牆保持淨空距離，並確認浮子開關機構不被入水水流干擾。
- ⑨ 完成安裝後必須清理水槽內所有雜物碎屑。
- ⑩ 閘閥或球閥由安裝者提供，並需依照所有相關規範安裝。
- ⑪ 如圖示安裝浮球開關。「停止」點的最佳位置為馬達外殼上方、與入口成180° 的方位。切勿將「停止」點配置在水泵出口以下。
- ⑫ 應使用氣密密封圈隔絕氣體與氣味。
- ⑬ 利用通氣管將氣體與氣味排出。

安裝示意圖

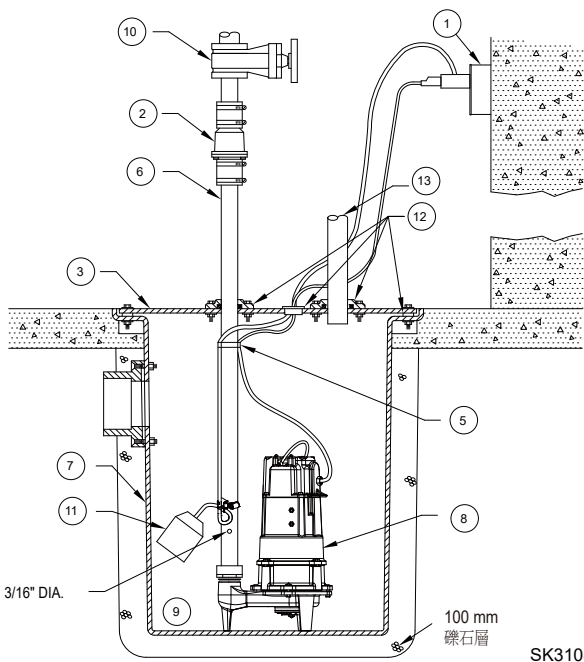

所有安裝作業必須符合適用的水電規範，至少包括現行電工規則、當地、區域及/或現行配管規則等。不適用於危險性場所。

鋼蓋板水池上標準浮子安裝桿

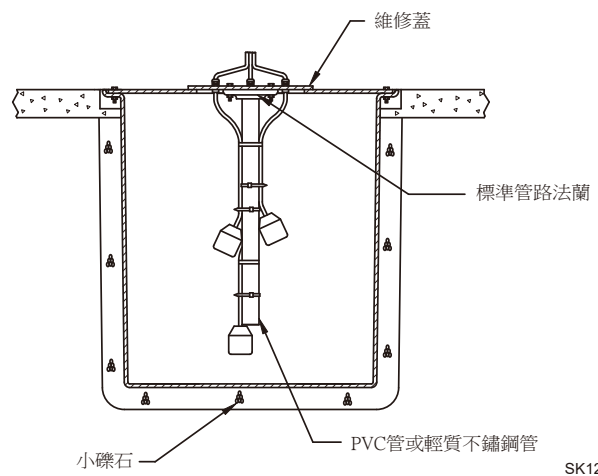

某些安裝場合可能需要利用獨立的浮子桿安裝各控制開關，以免牽掛到水泵、管路、閘門等。卓勒提供各種浮子桿，請參考FM0526型錄；也可利用標準管材與配件製作。

三相接線說明

2753 / 2755 / 2757 / 2763 / 2765 / 2767 型

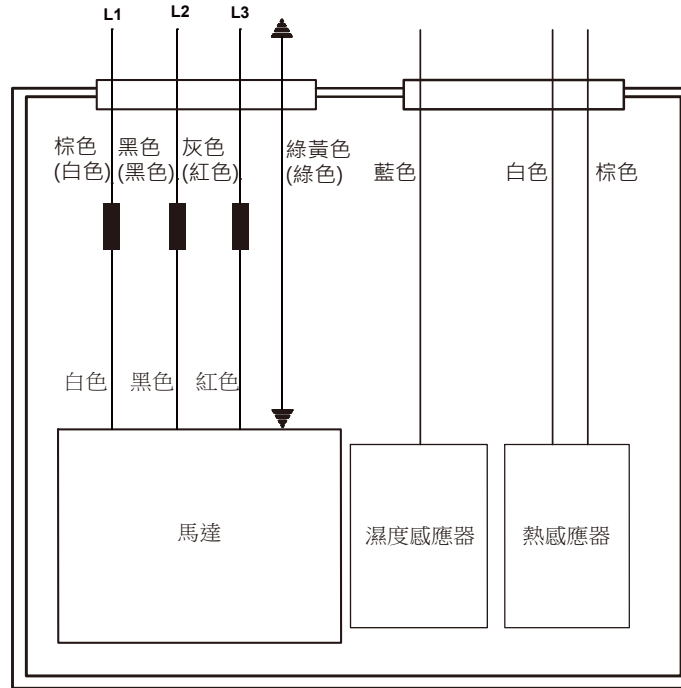

EA0116