

**Notice to Installer: Instructions must remain with installation.**

ZT0311\_ECb

Trusted. Tested. Tough<sup>®</sup>

0322

Product information presented here reflects conditions at time of publication. Consult factory regarding discrepancies or inconsistencies.

Supersedes

0818



**50 Hz**

Visit our website:  
[www.zoellerpumps.com](http://www.zoellerpumps.com)





Register your Zoeller Pump Company Product on our website: <http://reg.zoellerpumps.com/>

# INSTALLATION INSTRUCTIONS

2802 / 2812 / 2833 / 2835 / 2837

## PREINSTALLATION CHECKLIST - ALL INSTALLATIONS

- Inspect your pump.** Occasionally, products are damaged during shipment. If the unit is damaged, contact your dealer before using. **DO NOT** remove the test plugs in the cover nor the motor housing.
- Carefully read the literature** provided to familiarize yourself with specific details regarding installation and use. These materials should be retained for future reference.

 <div style="border: 1px solid black; padding: 5px; display: inline-block;"><b>WARNING</b></div> <b>SEE BELOW FOR LIST OF WARNINGS</b>	<h3 style="text-align: center;">SAFETY INSTRUCTIONS</h3>
<ol style="list-style-type: none"> <li>To reduce the risk of electrical shock, a properly grounded receptacle or control box must be installed in accordance with the governing codes. Never remove ground pin from plug.</li> <li>Make certain that the receptacle or control box is within reach of the pump's power supply cord. <b>DO NOT USE AN EXTENSION CORD.</b> Extension cords that are too long or too light do not deliver sufficient voltage to the pump motor, and they could present a safety hazard if the insulation were to become damaged or the connection end were to fall into a damp or wet area.</li> <li>Make sure the pump's electrical supply circuit is equipped with fuses or circuit breakers of proper capacity. A separate branch circuit is recommended, sized according to the governing electrical codes for the current shown on the pump name plate.</li> <li><b>Testing for ground.</b> As a safety measure, each electrical outlet should be checked for ground using a circuit analyzer which will indicate if the power, neutral and ground wires are correctly connected to your outlet. If they are not, call a qualified licensed electrician.</li> <li><b>FOR YOUR PROTECTION, ALWAYS DISCONNECT PUMP FROM ITS POWER SOURCE BEFORE HANDLING.</b> If pump is wired direct, de-energize the circuit at the control box. <b>DO NOT, UNDER ANY CIRCUMSTANCES, REMOVE THE GROUND PIN.</b> Wear insulated protective shoes and do not stand in water. Pumps equipped with a grounded plug are designed to help protect against electrical shock. A properly grounded receptacle or control box must be installed in accordance with governing codes.</li> <li>Installation and servicing of the pump's electrical circuits and hardware should only be performed by a qualified licensed electrician.</li> <li>Installation and maintenance of this appliance is not intended for persons (including children) with reduced physical, sensory or mental capabilities, or lack of experience or knowledge, unless they have been given supervision or instruction concerning use of the appliance by a person responsible for their safety.</li> <li><b>Risk of electrical shock.</b> Do not remove power supply cord and strain relief or connect conduit directly to the pump. If the supply cable is damaged, it must be replaced by an authorized Zoeller Representative.</li> <li>Pump may contain oil which becomes pressurized and hot when operating. Allow 2-1/2 hours after disconnecting before attempting service.</li> <li>Pump is not intended for potable water due to possible contamination by oil contained in the pump.</li> <li><b>Risk of electrical shock.</b> These pumps have not been investigated for use in swimming pools and marine areas.</li> </ol>	<p><b>TO AVOID SERIOUS OR FATAL PERSONAL INJURY OR MAJOR PROPERTY DAMAGE, READ AND FOLLOW ALL SAFETY INSTRUCTIONS IN THIS MANUAL AND ON THE PUMP.</b></p> <p><b>THIS MANUAL IS INTENDED TO ASSIST IN THE INSTALLATION AND OPERATION OF THIS UNIT AND MUST BE KEPT WITH THE PUMP.</b></p> <div style="margin-top: 20px;">  <p>This is a <b>SAFETY ALERT SYMBOL.</b> When you see this symbol on the pump or in the manual look for one of the following signal words and be alert to the potential for personal injury or property damage.</p> </div> <div style="margin-top: 10px;"> <div style="display: flex; align-items: center;"> <div style="border: 1px solid black; padding: 2px; margin-right: 5px;"><b>WARNING</b></div> <p>Warns of hazards that <b>CAN</b> cause serious personal injury, death or major property damage.</p> </div> </div> <div style="margin-top: 10px;"> <div style="display: flex; align-items: center;"> <div style="border: 1px solid black; padding: 2px; margin-right: 5px;"><b>CAUTION</b></div> <p>Warns of hazards that <b>CAN</b> cause personal injury or property damage.</p> </div> </div> <div style="margin-top: 10px;"> <div style="display: flex; align-items: center;">  <p>Warns of electrical shock hazards that <b>CAN</b> cause serious personal injury, death or major property damage.</p> </div> </div> <div style="margin-top: 10px;"> <div style="display: flex; align-items: center;">  <p>Identifies any terminal which is intended for connection to an external conductor for protection against electrical shock in case of a fault, or the terminal of a protective earth (ground) electrode.</p> </div> </div> <div style="margin-top: 10px;"> <div style="display: flex; align-items: center;">  <p>Read operator's manual.</p> </div> </div> <p><b>THOROUGHLY REVIEW ALL INSTRUCTIONS AND WARNINGS PRIOR TO PERFORMING ANY WORK ON THIS PUMP. MAINTAIN ALL SAFETY DECALS.</b></p>
<p>REFER TO WARRANTY ON PAGE 2.</p>	

**DO NOT USE FOR PUMPING OILS, GASOLINE OR ANY PETROLEUM BY-PRODUCTS.**

## CAUTION

### SEE BELOW FOR LIST OF CAUTIONS

1. Check to be sure your power source is capable of handling the voltage requirements of the motor, as indicated on the pump name plate.
2. The installation of variable level float switches is the responsibility of the installing party, and care should be taken that the tethered float switch will not hang up on the pump apparatus or pit peculiarities and is secured so that the pump will shut off. It is recommended to use rigid piping and fittings and the pit be 45 cm (18") or larger in diameter.
3. Vent hole. It is necessary that all submersible sump, effluent and sewage pumps capable of handling various sizes of solid waste be of the bottom intake design to reduce clogging and seal failures. If a check valve is incorporated in the installation, a 5 mm (3/16") vent hole must be drilled in the discharge pipe below the check valve and pit cover to purge the unit of trapped air. Vent hole should be checked periodically for clogging. The vent hole on a High Head application may cause too much turbulence. You may not want to drill one. If you choose not to drill a vent hole, be sure the pump case and impeller is covered with liquid before connecting the pipe to the check valve. **NOTE: THE HOLE MUST BE BELOW THE BASIN COVER AND CLEANED PERIODICALLY.** Water stream will be visible when pump is operating.
4. Pump should be checked frequently for debris and/or build up which may interfere with the float "on" or "off" position. Repair and service should be performed by an authorized Zoeller Company Representative only.
5. Do not operate a pump in an application where the Total Dynamic Head is less than the minimum Total Dynamic Head listed on the Pump Performance Curves.
6. For health reasons, do not unplug, turn off, or disable pump and use pump tank system as a way to fill up a sink or laundry tray, etc.

## LIMITED WARRANTY

Manufacturer warrants, to the purchaser and subsequent owner during the warranty period, every new product to be free from defects in material and workmanship under normal use and service, when properly used and maintained, for a period of one year from date of purchase by the end user, or 18 months from date of original manufacture of the product, whichever comes first. Parts that fail within the warranty period, one year from date of purchase by the end user, or 18 months from the date of original manufacture of the product, whichever comes first, that inspections determine to be defective in material or workmanship, will be repaired, replaced or remanufactured at Manufacturer's option, provided however, that by so doing we will not be obligated to replace an entire assembly, the entire mechanism or the complete unit. No allowance will be made for shipping charges, damages, labor or other charges that may occur due to product failure, repair or replacement.

This warranty does not apply to and there shall be no warranty for any material or product that has been disassembled without prior approval of Manufacturer, subjected to misuse, misapplication, neglect, alteration, accident or uncontrolled act of nature; that has not been installed, operated or maintained in accordance with Manufacturer's installation instructions; that has been exposed to outside substances including but not limited to the following: sand, gravel, cement, mud,

tar, hydrocarbons, hydrocarbon derivatives (oil, gasoline, solvents, etc.), or other abrasive or corrosive substances, wash towels or any other abusive entity, etc. in all pumping applications. The warranty set out in the paragraph above is in lieu of all other warranties expressed or implied; and we do not authorize any representative or other person to assume for us any other liability in connection with our products. Contact authorized distributors to obtain any needed repair or replacement of part(s) or additional information pertaining to our warranty.

MANUFACTURER EXPRESSLY DISCLAIMS LIABILITY FOR SPECIAL, CONSEQUENTIAL OR INCIDENTAL DAMAGES OR BREACH OF EXPRESSED OR IMPLIED WARRANTY; AND ANY IMPLIED WARRANTY OF FITNESS FOR A PARTICULAR PURPOSE AND OF MERCHANTABILITY SHALL BE LIMITED TO THE DURATION OF THE EXPRESSED WARRANTY.

Some jurisdictions do not allow limitations on the duration of an implied warranty, so the above limitation may not apply to you. Some jurisdictions do not allow the exclusion or limitation of incidental or consequential damages, so the above limitation or exclusion may not apply to you.

This warranty gives you specific legal rights and you may also have other rights which vary from jurisdiction to jurisdiction.

**In those instances where damages are incurred as a result of an alleged pump failure, the Homeowner must retain possession of the pump for investigation purposes.**

## EASY DO'S & DON'T'S FOR INSTALLING UNIT

1. **DO** read all installation material included with the pump.
2. **DO** inspect unit for any visible damage caused by shipping. Contact dealer if unit appears to be damaged.
3. **DO** remove all debris from the basin. Be sure that the pump will have a hard, level surface beneath it. **DO NOT** install on sand, gravel or dirt.
4. **DO** be sure that the area is large enough to allow proper clearance for the level control switch(es) to operate properly.
5. **DO always disconnect pump from power source before handling.** **DO** always connect to a separately protected and properly grounded circuit. **DO NOT** ever cut, splice or damage power cord (only splice in a watertight junction box). **DO NOT** carry or lift pump by its power cord. **DO NOT** use an extension cord.
6. **DO** install a check valve and a union in the discharge line. **DO NOT** use a discharge pipe smaller than the pump discharge size.
7. **DO NOT** utilize this unit for pumping gasoline or other hazardous liquids.
8. **DO** test pump immediately after installation to be sure that the system is working properly.
9. **DO** review all applicable local and national codes and verify that the installation conforms to each of them.
10. **DO** consult manufacturer for clarifications or questions.
11. **DO** consider a D.C. Backup System is necessary for the prevention of property damages from flooding due to A.C. power disruptions, mechanical or electrical problems or system overloading.
12. **DO** inspect and test system for proper operations at least every 3 months.

## General Maintenance

**▲ NOTICE** Repair and service should be performed by a Zoeller Pump Company Authorized Service Station only.

### SAFETY PROCEDURES



**▲ WARNING** For your protection, always disconnect pump and panel from its power source before handling.



**▲ WARNING** Never enter the basin until it has been properly vented and tested. Any person entering a basin should be wearing a harness with safety rope extending to the surface so that they can be pulled out in case of asphyxiation. Sewage water gives off methane and hydrogen sulfide gases, both of which can be highly poisonous.

Installation and checking of electrical circuits and hardware should be performed by a qualified electrician.

Pump is never to be lifted by power cord.



**▲ WARNING** Unit must be cleaned and disinfected, inside the pumping chamber and all exterior surfaces, prior to servicing.

### GENERAL SYSTEM INSPECTION

Before the system is placed into operation, it should be inspected by a qualified technician.



**▲ WARNING** Wiring and grounding must be in accordance with the National Electrical Code and all applicable local codes and ordinances.

### LUBRICATION PROCEDURES

No lubrication is required.

If pumps are to be stored for more than six months, refer to short-term storage procedure in the Operation section.

### PREVENTIVE MAINTENANCE

Preventive maintenance is recommended to ensure a long service life from the product. Provided is a suggested maintenance schedule.

#### Every six months:

- Inspect and test system for proper operation.
- Check for proper and unobstructed float operation.
- Listen for proper check valve operation.

#### Every 5 years or 10,000 hours of operation:

- Remove pump, inspect and service using a Zoeller rebuild kit.
- Flush and clean basin.

### DOUBLE SEAL PUMPS

Double seal pumps offer extra protection when these pumps are supplied with optional moisture sensors, check the control panel's seal failure light for a warning. Whenever the seal leak light is activated, it's indicating that moisture is present, and the pump should be removed and serviced in order to avoid damage to the motor.

## SERVICE CHECKLIST



**▲ WARNING ELECTRICAL PRECAUTIONS-** Before servicing a pump, always shut off the main power breaker and then unplug the pump. "Make sure you are wearing insulated protective sole shoes and not standing in water." Under flooded conditions, contact your local electric company or a qualified licensed electrician for disconnecting electrical service to the pump prior to removal.

**▲ WARNING** Submersible pumps contain oils which become pressurized and hot under operating conditions. **Allow 2-1/2 hours after disconnecting before attempting service.**

CONDITION	COMMON CAUSES
A. Pump will not start or run.	Check fuse, low voltage, overload open, open or incorrect wiring, open switch, impeller or seal bound mechanically, motor or wiring shorted. Float assembly held down. Switch damaged or out of adjustment.
B. Motor overheats and trips overload or blows fuse.	Incorrect voltage, negative head (discharge open lower than normal) impeller or seal bound mechanically, motor shorted.
C. Pump starts and stops too often.	Float switch tether length too short, check valve stuck open, or none installed in long distance line, overload open, bidding, sump pit too small.
D. Pump will not shut off.	Debris under float assembly, float or float rod bound by pit sides or other, switch defective, damaged or out of adjustment.
E. Pump operates but delivers little or no water.	Check inlet, strainer housing, discharge pipe, and vent holes for obstructions. Discharge head exceeds pump capacity. Low or incorrect voltage. Incoming water containing air or causing air to enter pumping chamber. Incorrect motor rotation. (3 phase pumps only.)
F. Drop in head and/or capacity after a period of use.	Increased pipe friction, clogged line or check valve. Abrasive material and adverse chemicals could possibly deteriorate impeller and pump housing. Check line. Remove base and inspect.

**If the above checklist does not reveal the problem, consult the factory. Do not attempt to service or otherwise disassemble pump. Service must be performed by an authorized Zoeller Company representative.**

## RECOMMENDED INSTALLATION FOR ALL APPLICATIONS

- (1) Electrical wiring and protection must be in accordance with National Electrical Code and any other applicable state and local electrical requirements.
- (2) Install proper Zoeller unichek (combination union and check valve), preferably just above the basin (indoor installations) to allow easy removal of the pump for cleaning or repair. If high head or below cover installation is required use 30-0164 on 1-1/2" (DN40) pipe, 30-0152 on 2" (DN50) pipe and 30-0160 on 3" (DN80) pipe.
- (3) All installations require a basin cover to prevent debris from falling into the basin and to prevent accidental injury.
- (4) When a Unichek is installed, drill a 5 mm (3/16") dia. hole in the discharge pipe even with the top of the pump. **NOTE: THE HOLE MUST ALSO BE BELOW THE BASIN COVER AND CLEANED PERIODICALLY.** (High Head unit see #3 under "Caution" on front page). Water stream will be visible from this hole during pump run periods.
- (5) Securely tape or clamp power cord to discharge pipe, clear of the float mechanism(s).
- (6) Use full-size discharge pipe.
- (7) Basin must be in accordance with applicable codes and specifications.
- (8) Pump must be level and float mechanism(s) clear of sides of basin before starting pump.
- (9) Basin must be clean and free of debris after installation.
- (10) Gate Valve or Ball Valve to be supplied by installer and installed according to any and all codes.
- (11) For nonautomatic pumps, locate float switches as shown in sketches. The best place for the "off" point is above the motor housing and positioned 180° from the inlet. Never put "off" point below discharge on pump.
- (12) Gas tight seals required to contain gases and odors.
- (13) Vent gases and odors to the atmosphere through vent pipe.

## INSTALLATION SKETCHES

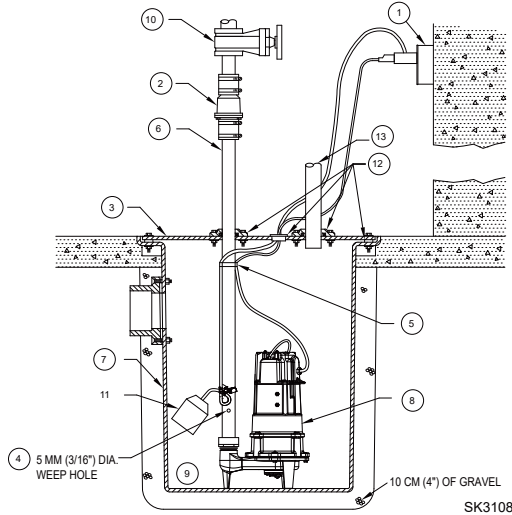

All installations must comply with all applicable electrical and plumbing codes.

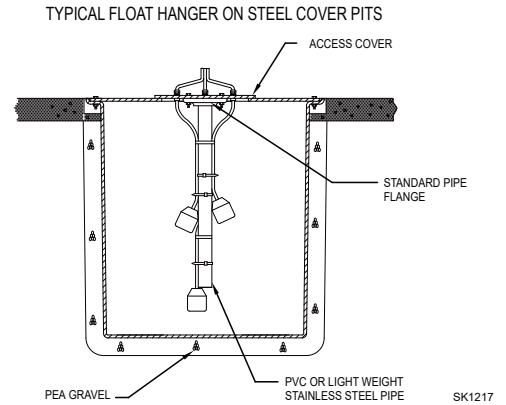

On some installations it may be desirable to install an independent hanger for the level control switches to avoid possible hang ups on the pumps, piping, valves, etc. Float hangers are available from Zoeller Company on Catalog Sheet FM0526 or can be fabricated from standard pipe and fittings.

## 3 PHASE WIRING DIAGRAM

### Model 2802 / 2812

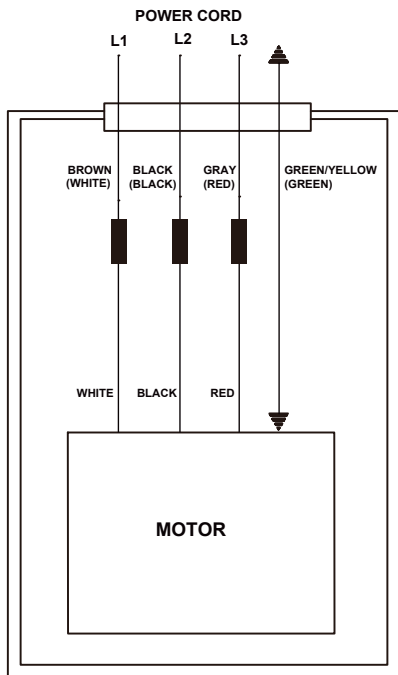

### Model 2833 / 2835 / 2837

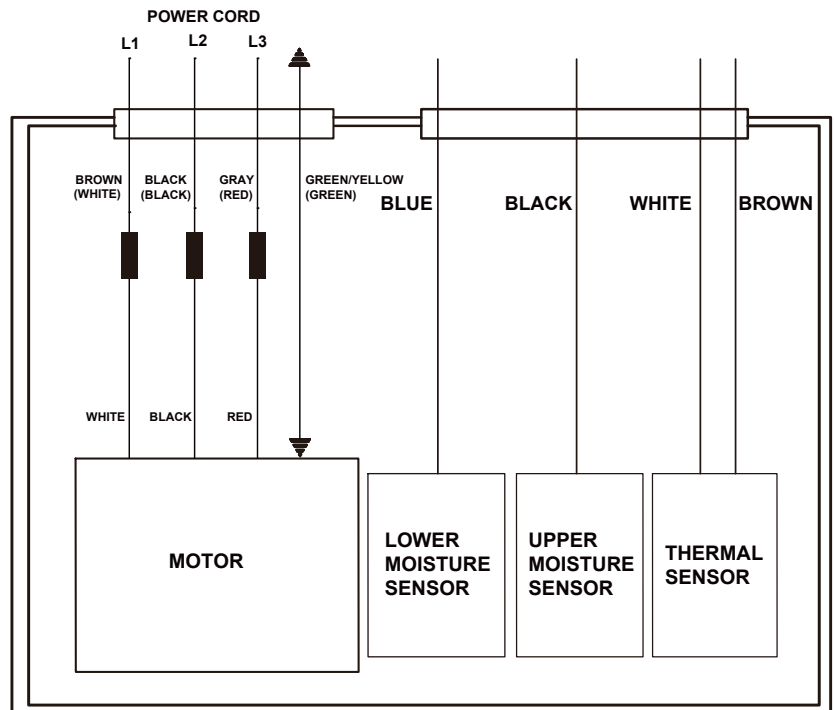

# SINGLE PHASE WIRING DIAGRAM

**Model 2802**

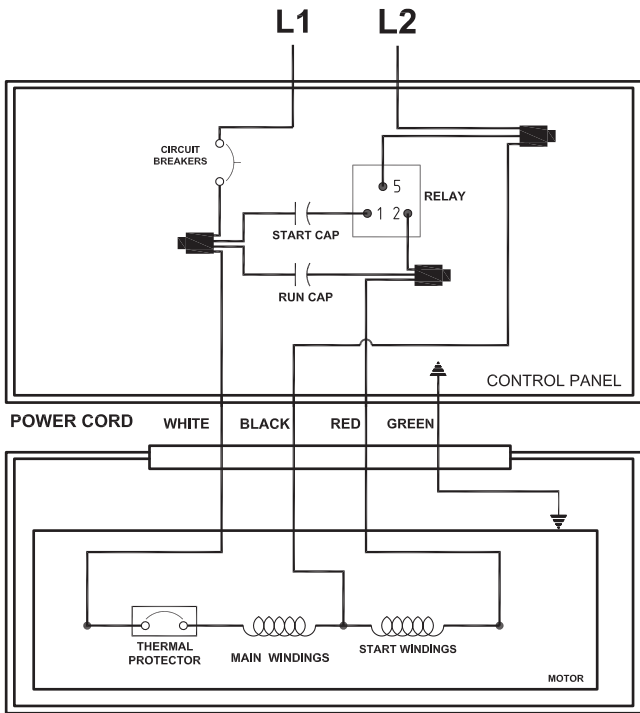

**Model 2812**

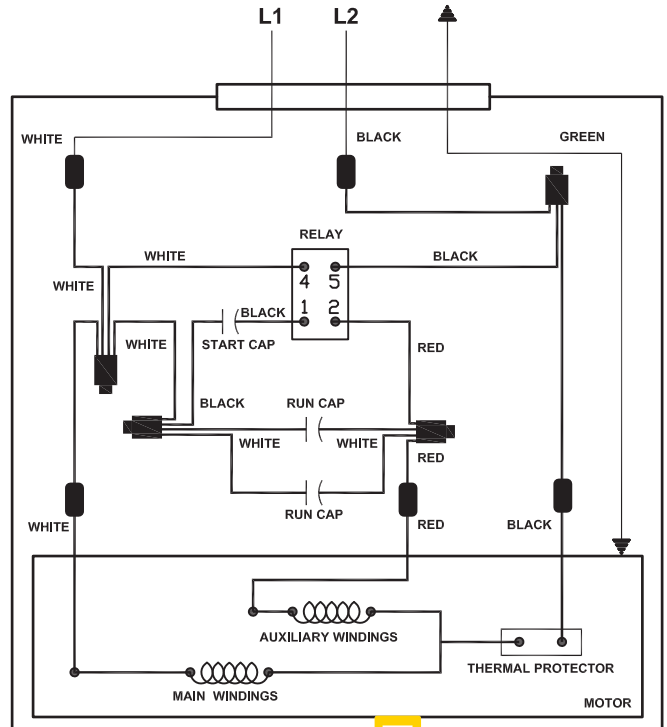

Model No.	Start Capacitor	Run Capacitor
2802	<b>400 <math>\mu</math>F</b> <b>250 VAC</b>	<b>90 <math>\mu</math>F</b> <b>250 VAC</b>
2812	<b>300 <math>\mu</math>F</b> <b>250 VAC</b>	<b>90 <math>\mu</math>F</b> two capacitors <b>350 VAC</b> (45 $\mu$ F,350 VAC) In parallel.

## 1 $\emptyset$ Connection Drawing for In Line Breaker (Push to Reset Type)

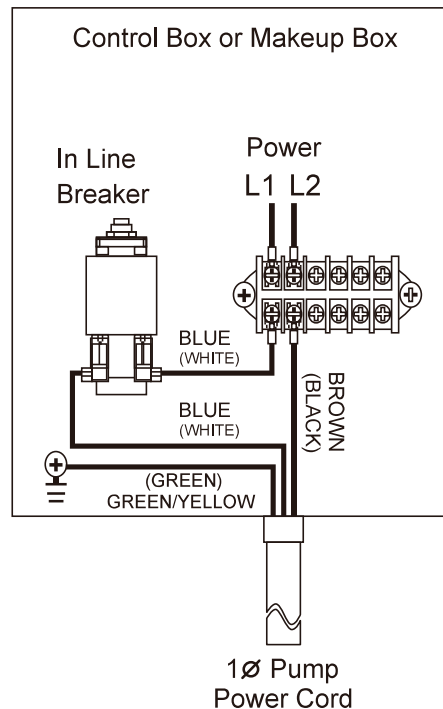
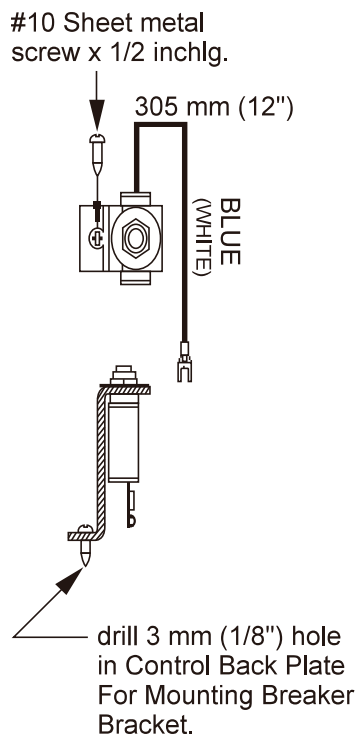

*These are the original installation instructions.*



# 安装前务必详读说明书

Trusted. Tested. Tough®

文件仅供参考  
若有任何修改  
恕不另行通知

请至美国卓勒水泵公司  
官网完成您的产品注册



50 Hz







Visit our website:  
[www.zoellerpumps.com](http://www.zoellerpumps.com)

## 安装说明书

2802 / 2812 / 2833 / 2835 / 2837

### 安装前检查

1. 安装前请仔细检查所有零件。产品如果在运送中受损，请尽速联络经销商。
2. 安装前仔细阅读所有提供的文件，熟悉安装细节，并保存资料以供未来参考。

 <b>警告</b>	<b>安全守则</b>
<ol style="list-style-type: none"><li>1. 为防范使用者触电，本公司所有产品皆配有包含接地功能的电线及三插插头。为确保安全，请勿将插头的接地插销拔除。</li><li>2. 为确保安全请勿使用延长线。加装延长线容易使水泵马达接收不到足够的电压。更重要的是，若延长线的绝缘遭破坏、或插头松脱掉入水中，将可能造成危险。</li><li>3. 请确认在供给水泵电源的电路中加装适当规格的保险丝或断路器。在此建议依照水泵铭牌上的电流值，并参照国内电工法则来选择及安装独立的断路器。</li><li>4. 请在安装前测试插座的漏电保护功能。为了安全考量，请使用符合国内电工法规的电路测试仪器来检查插座中的火线、中性线及地线是否配置正确。若发现异常，请联络合格的水电技师来为您解决问题。</li><li>5. 为了保护您的安全，接触水泵前请先拔除电源。如果水泵使用电线直接连接，需在电控箱内断电。任何情况下都不允许移除接地插销。确保人未站在水中，且穿上绝缘鞋。泵配有接地插头的设计，以帮助防止触电。必须按国内法规，正确安装接地的插座或控制箱。</li><li>6. 仅得由持有证照的合格水电技师来进行水泵安装、管路搭配及电路配线。</li><li>7. 若无监督本产品不适合给儿童、心智不健全或经验不足者使用，前述条件者使用本产品时，监督者应负全部安全责任。</li><li>8. 为避免触电，请勿移除电缆线。如果电缆线受损，请联络经销商或本公司核可的服务单位维修。</li><li>9. 本水泵含冷却油，在运作状态下会受压变热——断电后等待2.5小时再进行维修。</li><li>10. 水泵不可使用於饮用水，冷却油有可能会污染水质。</li><li>11. 为防范触电，本产品勿用於游泳池。</li></ol>	<p>为避免严重或致命的人身伤害及重大财产损失，请阅读并遵守水泵的所有安全操作说明。</p> <p>本说明书在协助安装和操作本机型时，必须符合水泵的安全操作守则。</p> <p> 这是一个安全警告符号。当你在水泵或说明书中看到此符号，请查询以下符号，并警惕人身伤害或发生财产损失的可能性。</p> <p> <b>WARNING</b> 警告，表示可能会导致严重的人身伤害、死亡或重大财产损失的危险。</p> <p> <b>CAUTION</b> 注意，表示可能会造成人身伤害或财产损失的危险。</p> <p> 电击危险警告，表示可能会导致严重的人身伤害、死亡或重大财产损失的危险。</p> <p> 接地标志，表示藉由连接外部导体之接地线，在故障时可防止触电发生。</p> <p> 阅读操作手册。</p> <p>使用水泵前，请彻底阅读本说明书内的说明和警告。并维护所有安全标签。</p> <p>保固请参阅第02页。</p>

请勿使用於油类、汽油、石油产品或含任何化学成分的液体。



## 注意

1. 检查并确认使用的电源符合水泵铭牌上的规格需求。
2. 安装含自动浮子开关或外接式自动浮子开关的自动型产品时，安装者有责任确保浮子摆放在正确位置，且不会卡在水泵机组或机坑壁边，以确保本产品能正常运作。建议使用硬水管做为配管。
3. 排气孔的目的：  
一般沉水型污水泵都是从底部抽水，以防止水泵阻塞和泄漏。空气会因此容易积在水泵或管路内，造成气锁。排气孔是为了将这些空气排出。因此，必须在逆止阀与机坑盖下的管路凿一排气孔(直径约5 mm)，用以排来自底部入水口的积存空气。积存的空气可能源自於水泵运作时的搅动，或於水槽乾涸时进入水

- 泵。排气孔应定期检验，排除阻塞。本产品运转时看见水从排气孔流出，为正常现象。
4. 时常检查是否有杂物卡住浮子。维修请洽本公司认可的维修站。
5. 请勿在总动力扬程低於性能曲线中扬程下限之场合使用。运转时需保持直立。请勿倾斜水泵。
6. 基於健康理由，不要使用水泵系统来注入水槽或洗衣机的水等。

## 保固说明

本产品的保固为自购买日起算的一年、或从工厂制造日期起算的18个月，以先到期者为准。若能证明产品的缺陷是由材料或制造过程造成，本公司将负责维修或更换。本公司保留决定是否维修或更换产品、零件或配件的权利。维修或更换期间买方所产生的费用或损失不在保固范围内。本公司无法控制的损坏不在保固范围内。

保固不适用于：

- (1) 未依照说明书安装、操作或维护所造成的故障或损坏。
- (2) 不当操作、意外或疏忽所造成故障或损坏。
- (3) 加装不属于本产品的零、配件。
- (4) 未依照当地法规进行安装所造成的危害。

(5) 将产品用在非原本设计的用途上所造成的损坏。(例：抽取沙、碎石、水泥、泥巴、沥青、碳氢化合物及其衍生物、汽油、化学溶剂或其他有腐蚀性的液体、毛巾、女性卫生用品等。)

保固零、配件的退回：在本保固下任何修理或更换需送回本公司或其他本公司所指定的维修服务点，运费需自付。在任何情况下本公司不承担其他责任，包含资产或设备的损坏、利润损失、等.....。

上述为本产品唯一的保固说明，任何人的修改或另做承诺皆为无效。

在因涉嫌产品故障而招致损害的情况下，财产拥有人必须保留该产品以供调查之用。

## 安装注意事项

1. 请务必阅读本装置之所有安装资料。
2. 请务必检查装置是否在运送中产生可见的损坏。若装置显示受损，请洽经销商。
3. 请务必清除水坑中之杂物。将水泵放置在坚固地面上。切勿将水泵放置在泥沙上。
4. 请务必确认水坑大小足以允许浮子自由活动。
5. 处理前切断水泵电源。连结到独立受保护的接地漏电流断路器。请勿切断、拼接或损坏电源线。请勿用电源线拉动或举起水泵。请勿使用延长线。
6. 请务必在出水管线安装止回阀和管接头。切勿使用小於出水口径尺寸的水管安装。

7. 切勿使用本装置抽取汽油或其他危险液体。
8. 请务必在安装后立即测试水泵，以确认系统正常运作。
9. 请务必详阅所有适用当地及国家规则，确认安装符合各项规定。
10. 若有疑问，请务必洽制造商查明。
11. 请务必考虑电池备用系统，以防停电或故障造成的财产损失。
12. 请务必每3个月检查一次系统是否正常运作。

# 一般维修

产品维修及维护须由 Zoeller 水泵公司授权之合格维修站来执行。

## 安全程序

- 为了您的安全考量,在执行作业前请先将水泵及控制面板上的电源插头拔除。
- 在没有适当地执行排气与测试前,请勿进入桶装地方。任何人进入桶装地方,须穿著安全护具并系上可延伸到地面的安全绳,以防人员窒息时可以被救出。污水会排放出甲烷和硫化氢气体,二者都是具有高毒性。
- 电路及其硬体设备安装及检查须由合格之电工人员来执行。
- 请勿用电源线来拉提水泵。
- 维修前,产品之内部水泵室和所有外部表面都必须进行清理和清洁。

## 一般系统检查

- 在系统被安装好开始运转前,须由合格工程技师执行检验。
- 电路与接地线必须符合国际电气规范以及适用于所有当地规范及条例。

## 上油程序

无上油作业需求。

如果水泵存放超过6个月,请参照短期存放作业的部分来进行。

## 预防性保养

为确保产品的长效运转寿命,建议作预防性保养。

## 每6个月:

- 检查并测试系统是否运转正常。
- 检查浮子运作是否正常且无阻碍。
- 倾听止回阀的运作是否正常。

## 每5年或10,000 小时运转:

- 使用Zoeller 的重组工具,来移除水泵,检查及维护。
- 冲洗及清洁桶装。

## 双轴封水泵:

当双轴封水泵连结选配的水气感应器时,水泵会提供额外的保护。请检视控制面板上的轴封失效警告灯。无论何时,只要此轴封泄漏灯亮起时,表示目前有水份存在,需移除水泵并作保养维护作业,以防止马达的损坏

# 检查清单

在维修沉水泵之前,须关闭总电源断路器,拔除水泵插头——确保人未站在水中,且穿上绝缘保护底的鞋子。

水溢流时,联络当地的电力公司,或有执照的合格电气技师,在移除管之前进行断电。

本水泵含冷却油,在运作状态下会受压变热——**断电後等待2.5 小时再进行维修。**

异常状况	可能原因	补救措施
<b>A. 水泵未开始运作。</b>	低电压、保险丝烧断、电路中断。	由合格电气技师检查保险丝和电路。
	叶轮卡住。	联络经销商。
	马达或电线短路。	
	浮子开关上有杂物。	去除杂物
<b>B. 马达过热造成跳电或保险丝烧断。</b>	电压错误、负扬程(出水口高度低於水泵)、叶轮或轴封卡死、电容器、继电器或马达短路。	联络经销商。
<b>C. 水泵启动停止次数太频繁。</b>	止回阀阻塞、无止回阀、热过载保护器启动或浮子有瑕疵。	联络经销商。
<b>D. 水泵不停止。</b>	浮子下方有杂物。	去除浮子周围的杂物。
	浮子开关故障。	联络经销商。
<b>E. 水泵运转正常,但抽不到水或水流量太少</b>	进水口周围有杂物。	清理进水口附近区域。
	排放管堵塞。	必要时卸除排放管,冲走杂物。
	电压太低或不当电压。	由合格电气技师检查家庭管线。
	叶轮受损。	联络经销商。
	马达运转不当、电容器瑕疵、入水含空气或造成空气进入水机室。	联络经销商。
	水泵气锁。	确保排放管中的通气孔畅通。
	安装扬程超过系统设计的扬程。	更换排放管或联络经销商。
<b>F. 扬程或流量使用一般时间后降低。</b>	管路或止回阀阻塞。磨蚀性物质及有害的化学物质造成叶轮及水机损坏。	检查管路、打开并检查水机。

如果检查后仍无法排除问题,请与Zoeller公司授权的经销商联络,切勿自行拆卸水泵。



# 安装说明

- ① 电气配线及保护措施需符合相关电气规范与当地其他应用惯例之需求。
- ② 请在水槽稍高处安装适当的活接与止回阀组合组件，以便於拆卸水泵供清洁整理或维修。如果在安装上高度超出或低於桶盖时，需於1½"(DN40)水管上使用30-0164管件，2"(DN50)水管上使用30-0152管件，3"(DN80)水管上使用30-0160的管件。
- ③ 所有安装需使用水槽盖板防止杂物掉入水槽，并防止人员意外受伤。
- ④ 请在水泵水管钻一直径5 mm小孔，为避免通气孔水流影响对浮子的正常运作，通气孔的位置请避免面向浮子。建议钻孔位置低於"停止"水位，建议向下45度角可降低水流撞击桶盖产生的噪音。注：该孔需低於水槽盖板，并需定期清理，水泵运转时可看见该小孔有水流出。
- ⑤ 用束带将电源线在出水管上固定牢靠，并使其避开浮子开关机构。
- ⑥ 出水管管径不可小於水泵出口口径。
- ⑦ 水槽需符合适用规范及规格。
- ⑧ 启动水泵前确认水泵水平，且浮子开关机构与水槽边墙保持净空距离，并确认浮子开关机构不被入水水流干扰。
- ⑨ 完成安装后必须清理水槽内所有杂物碎屑。
- ⑩ 闸阀或球阀由安装者提供，并需依照所有相关规范安装。
- ⑪ 如图示安装浮子开关。「停止」点的最佳位置为马达外壳上方、与入口成180°的方位。切勿将「停止」点配置在水泵出口以下。
- ⑫ 应使用气密密封圈隔绝气体与气味。
- ⑬ 利用通气管将气体与气味排出。

# 安装示意图

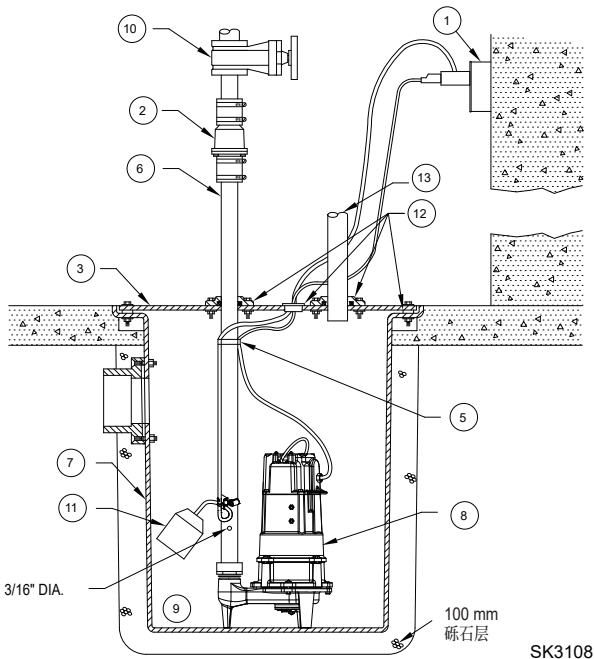

所有安装作业必须符合适用的水电规范，至少包括现行电工规则、当地、区域及 / 或现行配管规则等。不适用于危险性场所。

钢盖板水池上标准浮子安装杆

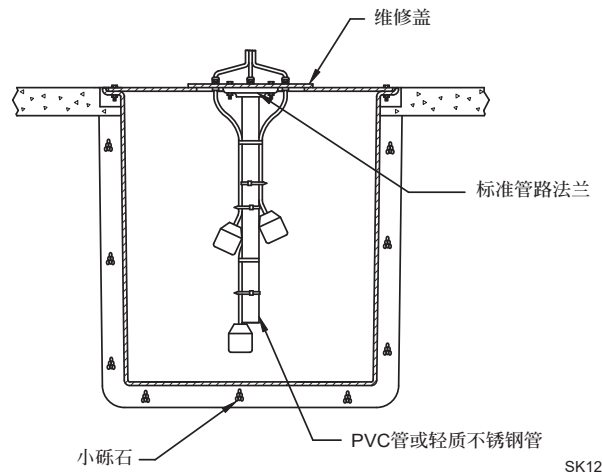

某些安装场合可能需要利用独立的浮子杆安装各控制开关，以免牵挂到水泵、管路、阀门等。卓勒提供各种浮子杆，请参考FM0526型录；也可利用标准管材与配件制作。

# 三相接线说明

## 2802 / 2812 型

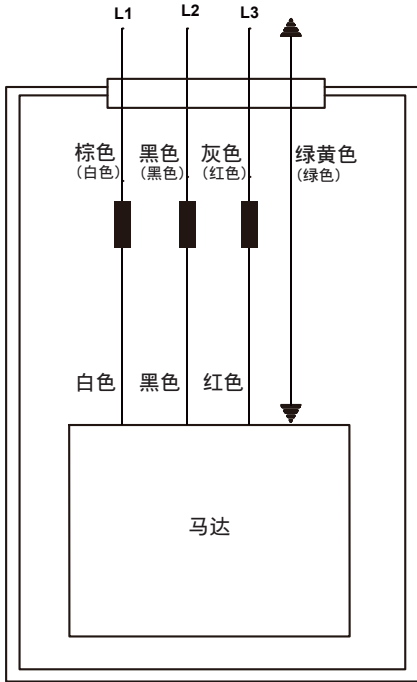

EA0115

## 2833 / 2835 / 2837 型

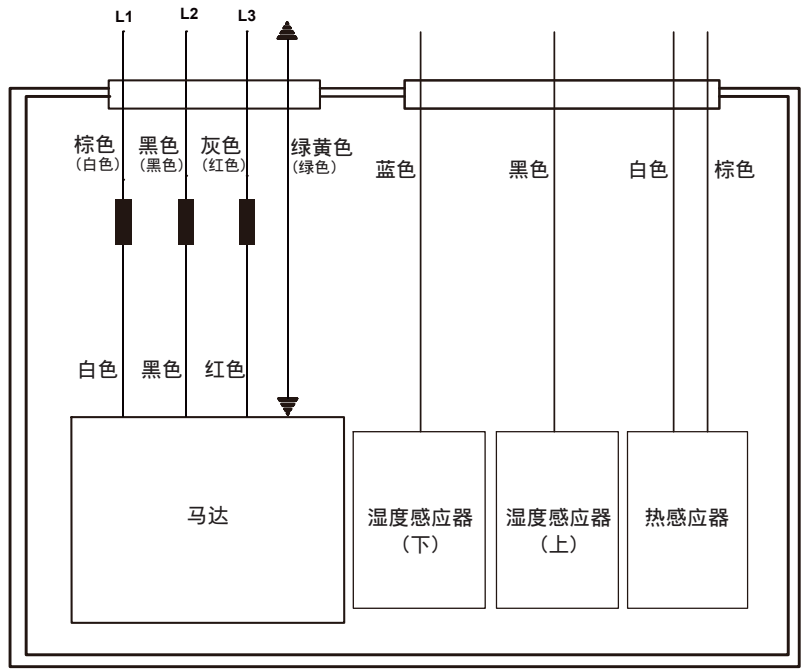

EA0116

# 单相接线说明

## Model 2802

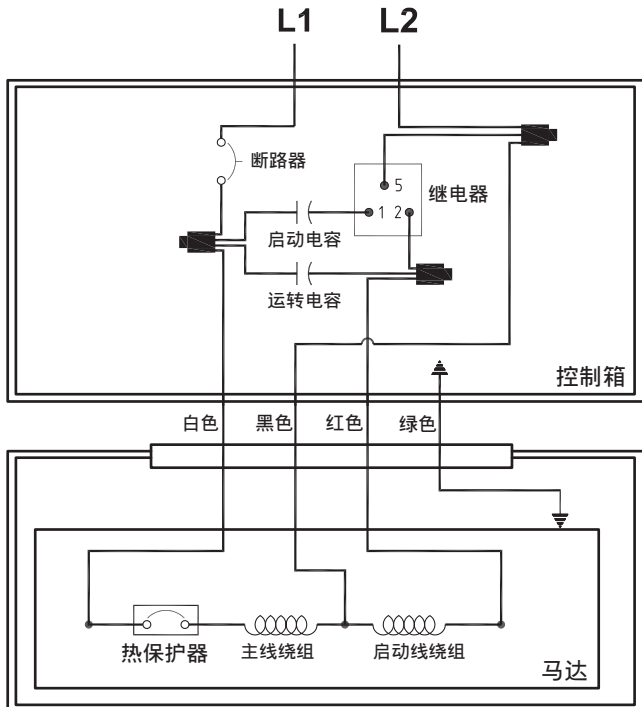

## Model 2812

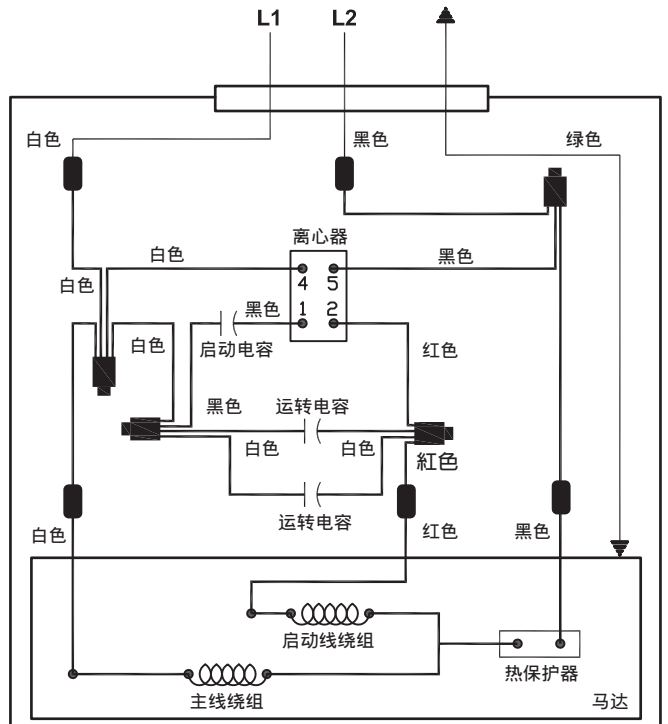

型号	启动电容	运转电容
2802	400 $\mu$ F 250 VAC	90 $\mu$ F 250 VAC
2812	300 $\mu$ F 250 VAC	90 $\mu$ F 两个并联的电容 350 VAC (45 $\mu$ F, 350VAC)

# 单相断路器接线图（手动复归型）

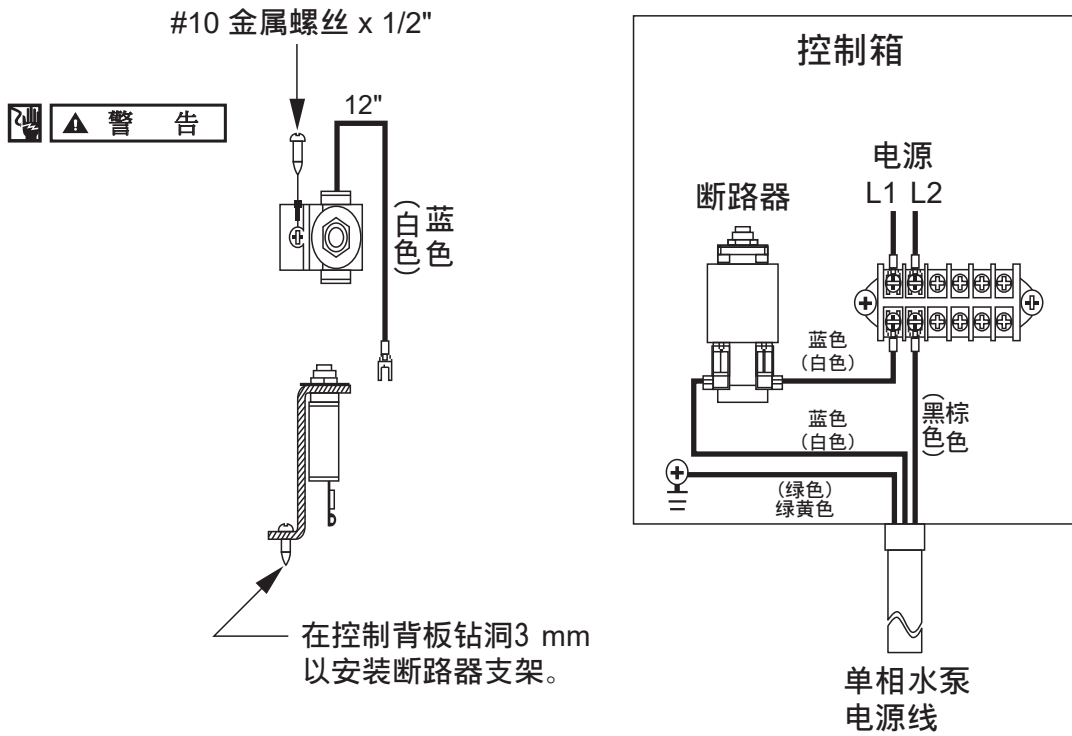

这是原始安装说明的翻译资料。