

Qwik Alarm[®] for Qwik Jon[®] Choice

Protect your investment!

FOR BATHROOM INSTALLATIONS

Features and Benefits:

- An audible alarm that alerts when the tank water level is high
- Convenient snap-fit cover provides easy access to alarm settings and the battery compartment
- Smooth white polypropylene case that is easy to clean
- Preassembled alarm and seal for quick and easy installation
- Low profile, compact design blends in well in a bathroom setting
- IPX8 rated device that can withstand periods of total immersion, so it is ideal for damp areas

100% factory tested

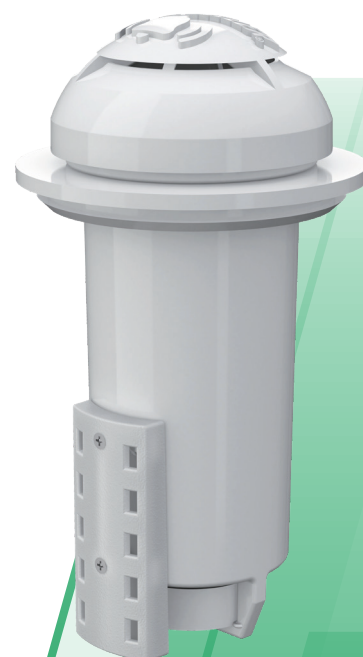

10-5089



Trusted. Tested. Tough.[®]

ZT0559_Ec
0122
Supersedes
NEW

**Vented (10-5089) - for use on the Qwik Jon® Chioce
when a carbon filter vent is permissible**

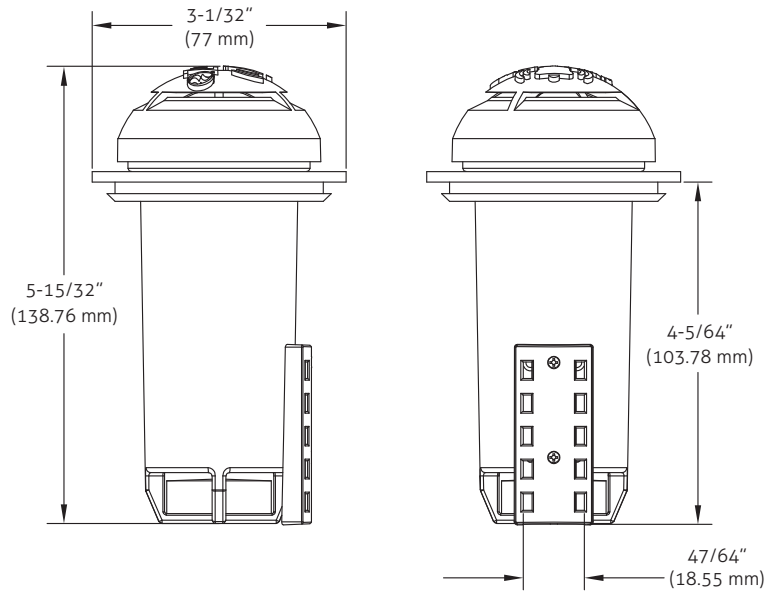

Install in a bathroom anywhere



Workshops



Basements



Apartment remodels



Cabins



Room additions

Product information presented here reflects conditions at time of publication.
Consult factory regarding discrepancies or inconsistencies.

© Copyright 2022 Zoeller® Co. All rights reserved.
www.zoellerpumps.com

