

# Qwik Alarm<sup>®</sup> for Qwik Jon<sup>®</sup> Premier

Protect your investment!

## FOR BATHROOM INSTALLATIONS

### Features and Benefits:

- An audible alarm that alerts when the tank water level is high
- Convenient snap-fit cover provides easy access to alarm settings and the battery compartment
- Smooth white polypropylene case that is easy to clean
- Preassembled alarm and seal for quick and easy installation
- Low profile, compact design blends in well in a bathroom setting
- IPX8 rated device that can withstand periods of total immersion, so it is ideal for damp areas

**100% factory tested**



10-5090

**ZOELLER**<sup>®</sup>   
PUMP COMPANY

Trusted. Tested. Tough.<sup>®</sup>

FM3430  
0122  
Supersedes  
NEW

**Standard (10-5090) - for use on the Qwik Jon® Premier  
where a separate vent is used**

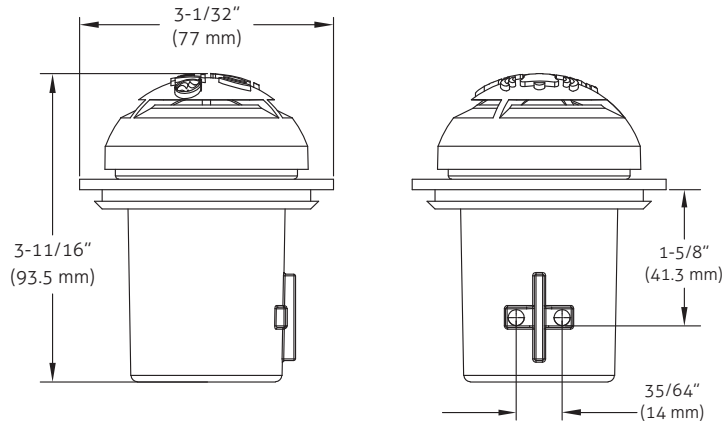

***Install in a bathroom anywhere***



Workshops



Basements

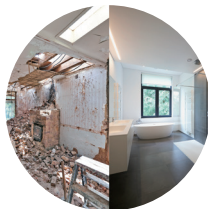

Apartment remodels



Cabins



Room additions

Product information presented here reflects conditions at time of publication.  
Consult factory regarding discrepancies or inconsistencies.

© Copyright 2022 Zoeller® Co. All rights reserved.  
[www.zoellerpumps.com](http://www.zoellerpumps.com)

