

Qwik Jon®

ELONGATED TOILET

Making bathroom installations easy!

Features and Benefits:

- Rear outlet toilet making it a perfect option for when ground flushing models will not work
- With the rear outlet, eliminate tearing up the floor to connect the toilet
- Easier installation and repairs. There is no need for lifting the toilet and disrupting the wax seal
- Standard elongated bowl and decorative tank with left-hand flush lever
- Soft closing hinged toilet seat that will prolong the life of the seat
- 1.28 gallons per flush
- ADA compliant toilet height
- Pairs with the Qwik Jon Premier or Qwik Jon Choice for a complete bathroom



ZOELLER® 
PUMP COMPANY

Trusted. Tested. Tough.®

FM3418
0522
Supersedes
NEW

Qwik Jon® ELONGATED TOILET



202-3002



202-2000



10-3050



Model 202 meets the Americans with Disabilities Act guidelines and ANSI A117.1 requirements for accessible and usable facilities — check local codes



Product information presented reflects conditions at time of publication. Consult factory regarding discrepancies or inconsistencies.

© Copyright 2022 Zoeller® Co.
All rights reserved.

Total Dimensions

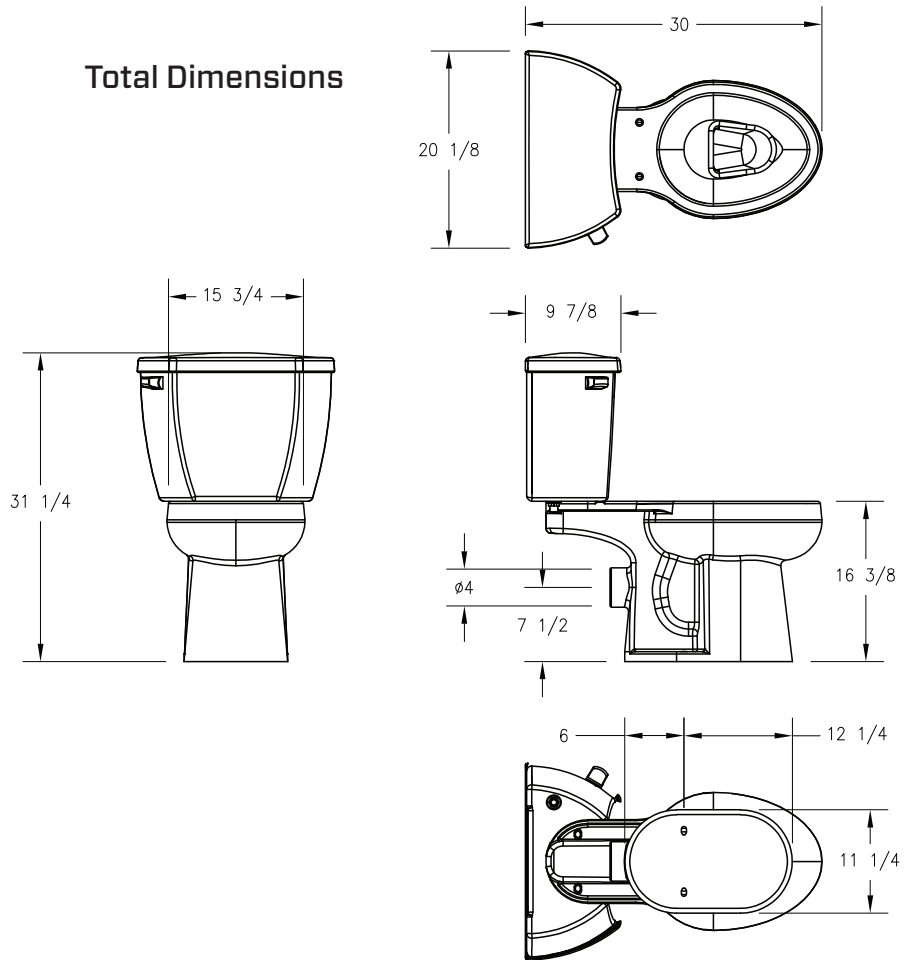

Part numbers and Qwik Jon® packages containing the toilet:

| Part # | Product |
|----------|---|
| 202-2000 | Qwik Jon® elongated toilet bowl |
| 202-3002 | Qwik Jon® toilet tank |
| 200-0021 | 1 box system. Toilet tank, elongated bowl, Qwik Jon Choice Macerator Ships on a skid |
| 201-0021 | 1 box system. Toilet tank, elongated bowl, Qwik Jon Premier Grinder Ships on a skid |
| 200-4000 | 3 boxes per system. Toilet tank, elongated bowl, Qwik Jon Choice Macerator Preferred shipping method for online orders |
| 201-4000 | 3 boxes per system. Toilet tank, elongated bowl, Qwik Jon Premier Grinder Preferred shipping method for online orders |
| 10-3050 | Optional extension kit (available for recessed or behind the wall installations) |

zoellerpumps.com

