

Trusted. Tested. Tough.®

Product information presented here reflects conditions at time of publication. Consult factory regarding discrepancies or inconsistencies.



SECTION: C3.10.140

CL0056

0122

Supersedes

1220

Register your Zoeller Pump Product on our website:

to Zoeller Reg page



MAIL TO: P.O. BOX 16347 • Louisville, KY 40256-0347
SHIP TO: 3649 Cane Run Road • Louisville, KY 40211-1961
TEL: (502) 778-2731 • 1 (800) 928-PUMP • FAX: (502) 774-3624

Visit our website: zoellerpumps.com

Clarus Fusion® Series Treatment Systems

OWNER'S MANUAL

Thank you for choosing a Fusion® Series Treatment System. High quality workmanship and easy maintenance have been incorporated into the Fusion® system. The system will provide years of trouble-free service when maintained according to the manufacturer's recommendations. Please read this manual in its entirety before using the Fusion®, and follow all instructions to ensure proper operation. Keep this manual for future reference along with other important onsite documents. Should further assistance be necessary, please contact Clarus Fusion® at 1-800-928-7867 or +1-502-778-2731.

Warning Labels

You will find warning labels on the Fusion®, riser lids, blower, and the alarm control panel. It is very important to follow the information on these labels to ensure your safety. Please do not remove these labels.



WARNING

SEE LIST BELOW FOR WARNINGS

- 1. DO NOT attempt to service the Fusion® unit yourself. Contact your authorized maintenance provider for all service related issues.
2. There are buried electrical cables and piping near and around the Fusion®. Please consult your authorized maintenance provider to locate these utilities before excavation.
3. DO NOT bury or cover the Fusion® lids with soil or other debris. This is necessary to allow access for operation and maintenance of the unit.
4. The Fusion® blower must be unobstructed and vented for proper operation. Care must be taken that no grass clippings or other materials accumulate on or around the blower and block ventilation.
5. DO NOT place heavy objects over the Fusion® or drive heavy equipment over the Fusion®, as damage may occur. Damage of this kind is not covered by the warranty.
6. DO NOT plant trees within 15 feet (4.6 m) of the Fusion® Series Treatment System.

TABLE OF CONTENTS

Limited Warranty 1
Process Description 3
System Components and Care 3
Excavation and Installation. 6
Start Up 9
Blower Timer Setting 11
Operation and Maintenance 12
Aeration Chamber Cleaning 14
Fusion® Pumping. 15
Troubleshooting 16

Fusion® Model: [] ZF-450 [] ZF-800
Serial No. _____
Installing Contractor _____
Phone Number _____
Installation Date _____
Maintenance Provider's Name _____
Phone Number _____

LIMITED WARRANTY

Manufacturer warrants, to the purchaser and subsequent owner during the warranty period, which is retroactive to the date of June 1, 2014 for previously installed Fusions, the Fusion® Fiberglass Tank only to be free from defects in material and workmanship under normal use and service, when properly installed, used and maintained, for a period of ten (10) years from date of purchase by the end user. Tanks that fail within the warranty period that inspections determine to be defective in material or workmanship, will be repaired, replaced or remanufactured at Manufacturer's option, provided that by so doing the manufacturer will not be obligated to replace the entire assembly or the complete unit. No allowance will be made for shipping charges, damages, labor or other charges that may occur due to product failure, repair or replacement.

All other Fusion® components including the blower and alarm panel will be warranted for a two-year (2) period from date of purchase by the end user. This warranty does not apply to and there shall be no warranty for any material or product that has been disassembled, subjected to misuse, misapplication, neglect, alteration, accident or act of God; that has not been installed, operated or maintained in accordance with Manufacturer's installation instructions; that has been exposed to outside substances including but not limited to the following: tar, hydrocarbons, hydrocarbon derivatives (oil, gasoline, solvents, etc.), or other abrasive or corrosive substances that can damage the fiberglass

material. The warranty set out in the paragraph above is in lieu of all other warranties expressed or implied; and we do not authorize any representative or other person to assume for us any other liability in connection with our products.

Contact Manufacturer at, 3649 Cane Run Road, Louisville, Kentucky 40211, Attention: Customer Support Department to obtain additional information pertaining to our warranty.

MANUFACTURER EXPRESSLY DISCLAIMS LIABILITY FOR SPECIAL, CONSEQUENTIAL OR INCIDENTAL DAMAGES OR BREACH OF EXPRESSED OR IMPLIED WARRANTY; AND ANY IMPLIED WARRANTY OF FITNESS FOR A PARTICULAR PURPOSE AND OF MERCHANTABILITY SHALL BE LIMITED TO THE DURATION OF THE EXPRESSED WARRANTY.

Some states do not allow limitations on the duration of an implied warranty, so the above limitation may not apply to you. Some states do not allow the exclusion or limitation of incidental or consequential damages, so the above limitation or exclusion may not apply to you.

This warranty gives you specific legal rights and you may also have other rights which vary from state to state.

HOW A FUSION® SERIES TREATMENT SYSTEM WORKS

The Fusion® is simple in design, yet advanced in its wastewater treatment ability. The design has been refined over many years of intense research and development in an effort to perfect this superior treatment system. Fusion® systems are 90% - 95% efficient at treating wastewater. This is nearly twice as effective as a traditional septic tank, which is approximately 50% efficient. This high degree of treatment helps to protect both your personal property and the environment.

The Fusion® utilizes a combination of anaerobic (without oxygen) and aerobic (with oxygen) biological processes to treat wastewater. As wastewater enters the Fusion®, it is broken down and becomes

food for biological organisms beneficial to bacteria operating within the unit. The first chamber serves to separate grease and large solids from the liquid. In the second chamber, plastic media with large surface areas are used to increase contact between water and beneficial bacteria to optimize treatment. A small linear air blower is used to move air (oxygen) into the third chamber for the aerobic process. The final effluent leaving the system will have been treated to secondary quality effluent and will average *9 mg/L CBOD₅ and 9mg/L TSS.

* Based on NSF Standard 40 testing.

Figure 1 - The following diagram will help you to better understand the process:

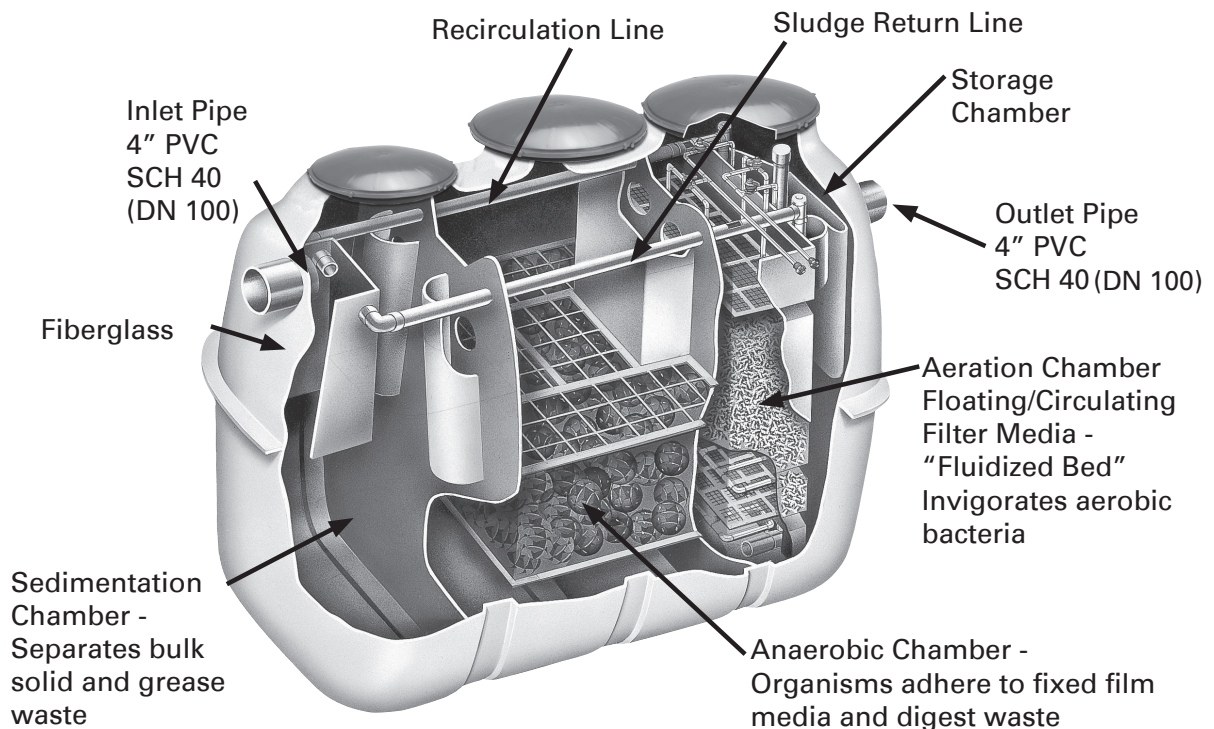
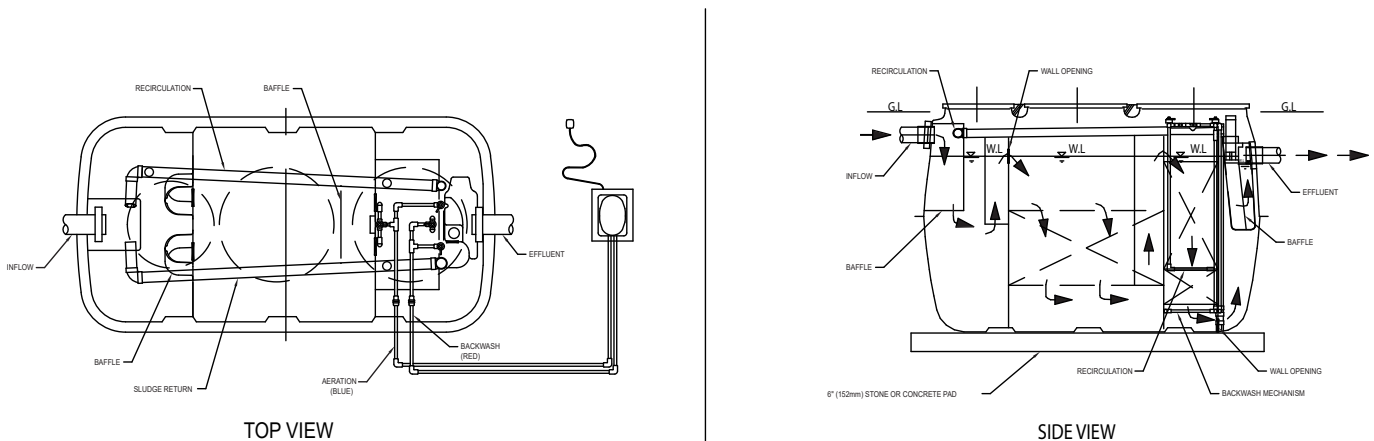

Figure 2 - Schematic diagram of the Fusion® Treatment System



SK3194

PROCESS DESCRIPTION

- 1. Sedimentation Chamber**
This chamber is designed to physically separate solids from the incoming water. Scum is the floating material and sludge is the material that has settled at the bottom.
- 2. Anaerobic Chamber**
This chamber contains a spherical skeleton-type filter media, 4.3 inch diameter (109 mm). Through bacterial growth processes on the surface of the filter media, biological anaerobic treatment thrives while suspended solids are captured. Furthermore, the microorganisms in this chamber convert nitrates in the recirculated water returning from the aerobic chamber to gaseous nitrogen. The gaseous nitrogen then escapes to the atmosphere.
- 3. Aeration Chamber**
The aeration chamber consists of an aerated upper section and a filter media lower section. The chamber is filled with hollow, cylindrical filter media, 0.6 inch diameter (15 mm)

and 0.55 inches long (14 mm). Biological treatment takes place on the filter media surface. Aeration is continuous. Residual suspended solids are captured by the filter media circulating in this section. During normal operation, a recirculation line transfers water back to the sedimentation chamber.

The filter media in the aeration chamber are backwashed regularly (twice a day, 5 or 10 minute cycle) by the backwash system located at the bottom of the chamber. The accumulated sludge is transferred back into the sedimentation chamber for further digestion.

- 4. Storage Chamber**
This chamber is designed to temporarily store treated water exiting the aeration chamber. This treated water is ready for discharge.

Figure 3 - Treatment Flow of the Fusion® System.

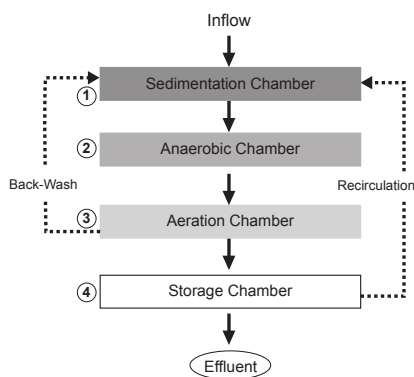

Figure 4

NSF STANDARD 40, CLASS 1, CERTIFICATION MARK



The NSF mark displayed here will be on all NSF Standard 40, Class 1 certified Fusion® systems. The Fusion® models ZF-450 and ZF-800 will have the mark displayed on the alarm panel. Systems not NSF Standard 40, Class 1 certified, will not display the mark.

SYSTEM COMPONENTS

The complete wastewater treatment system will typically consist of the Fusion® treatment components and a soil absorption field for final disposal of the liquid effluent. Some states or counties may require the addition of a septic tank before the Fusion® to increase the sedimentation chamber capacity and retain more solids. Please see Figure 11 for a typical Fusion® system. Variations to the typical system will be made to suit your particular site and system design needs. Please contact your authorized Fusion® installer or maintenance provider for further information about your system design.

THE FUSION® DUAL-PORT BLOWER

The Fusion® treatment unit utilizes an electronic, dual-port blower designed specifically for use with this system. The blower consists of a linear motor and two diaphragms to generate the air flow necessary to aerate and recirculate water within the system. This style of blower is quieter and more efficient than traditional rotary vane compressors. Once installed and adjusted, circuitry within the blower will automatically switch the unit from normal recirculation mode to backwash mode and back again when appropriate. In the event of a power outage, the blower will stop, but a backup battery within the unit will retain the correct time and backwash settings.

Usage Conditions

| Item | Use conditions |
|--------------------------|--|
| Operation | Continuous operation (outdoor use) |
| Installation | Should be level |
| Ambient Temperature | 41 °F - 104 F(5 C - 40 C) natural ambient temperature. |
| Range of pressure | 5.0 - 27.5 kPa |
| Rated operating pressure | 14.7 kPa |

Characteristics and Performance

| Item | DUO-80 | Test Method |
|---------------------------------|---|---------------------|
| Rating | | |
| Voltage | AC120V | |
| Frequency | 60Hz | |
| Insulation class | A Rank | |
| Operating time | Continuous | |
| CHARACTERISTICS AND PERFORMANCE | | |
| | 60 Hz | |
| Voltage(V) | AC 120V | Voltmeter |
| Current (A) | 0.88 or less | Ammeter |
| Air volume (L/min) | +20% 80 -10% | Mass Flowmeter |
| Temperature rise | 140 F (60 °C) or less at 86 °F (30 °C) room temperature | Thermo pen recorder |

Note: * The above performance is a stable state at a pressure (14.7kPa) and a value at room temperature in an atmosphere 68 - 77 °F (20 to 25 °C)
* The air flow rate value referred to the amount of air flowing at a temperature of 68 °F (20 °C), an absolute pressure of 101.3 kPa, and a relative humidity of 65% per unit time.

DATAPLATE

A dataplate similar to the one in Figure 5 is located on the blower housing and the alarm panel. There is important information about the Fusion® on the dataplate, such as the part number, model number, serial number, and hydraulic capacity. Please make a note of this information for future reference or in case you should need to contact your Fusion® maintenance provider.

The contracting installer must mark the installed model number on the dataplate, the blower housing and the alarm control panel.

Figure 5

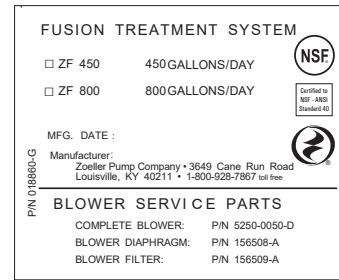

ALARM PANEL

The Fusion® utilizes an alarm panel (see Figure 6) that is designed to activate an audible buzzer and red beacon light on top of the panel if there is a drop in air pressure, if a high water alarm condition occurs, or if the blower does not cycle between recirculation and backwash modes within the preset time. (Note: Alarm panel can only function as long as there is electrical power supplied to the panel)

You may from time to time check the proper operation of the alarm panel by toggling the black switch on the side of the panel to “test”. The buzzer will sound and the red beacon will light as long as you hold the switch in the test position. Release the switch for normal operation.

Figure 6

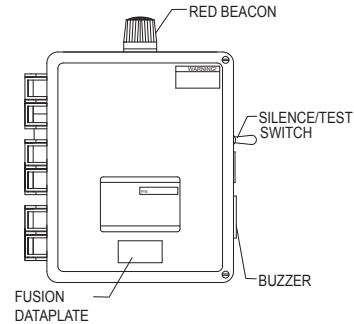

SYSTEM CARE

The Fusion® system is designed to continuously operate automatically with little direct maintenance from the owner. Periodically, a check of the blower area is recommended to ensure no debris obstructs the ventilation or intake areas of the blower. Also, periodically test the control panel as outlined under the alarm panel section. The owner should closely monitor the types and amounts of substances and products used. Water use should also be closely monitored to ensure proper operation of the Fusion® system.

Periodically, more extensive maintenance must be performed. Your authorized Fusion® maintenance provider will oversee this service. The name of the maintenance provider can be recorded on the front of this document and should also be located on the alarm panel. For more information see the Operation and Maintenance section of the manual.

The owner should only perform minimal routine maintenance on the Fusion® such as clearing debris from around blower housing (leaves, snow, and grass clippings). The Fusion® should also be protected from excessive weight such as vehicular traffic. Trees and bushes should not be planted in close proximity to the Fusion®. The Fusion® should be accessible to maintenance personnel and the riser lids must never be buried.

Figure 7

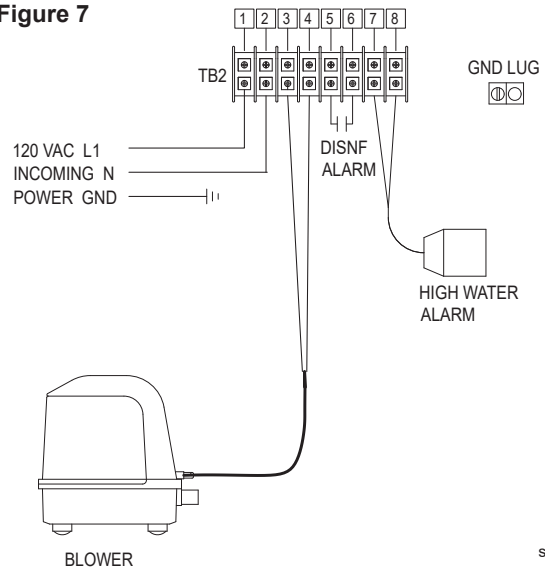

HIGH USE WATER DEVICES

The draining of hot tubs and swimming pools into your Fusion® system will cause hydraulic overloading and will impair the treatment efficiency. Please drain these devices to another location. Contact your local regulatory authorities or authorized Fusion® maintenance provider for more information. The use of large capacity single fill and drain whirlpool bathtubs may also cause hydraulic overloading of your Fusion®. Please limit the use of these types of tubs.

FLOODING

▲ NOTICE If flooding of the Fusion® occurs and the blower or the alarm panel is submerged, please disconnect power at the circuit breaker. DO NOT try to reconnect power to either the blower or alarm panel once it has been submerged. Immediately contact your authorized Fusion® maintenance provider to inspect the Fusion®, the blower, and the alarm panel. Your maintenance provider will repair or replace the components as needed.

LEAKY FIXTURES

It is very important to monitor all water fixtures in the home for leaks and drips and repair them immediately. Leaks can cause tremendous water use and may hydraulically overload your Fusion® system and reduce its treatment efficiency. Excessive water use may also overload your soil absorption field and cause failure.

INTERMITTENT USE

The Fusion® system is designed to function even if wastewater does not enter it for extended periods of time. The power to the blower must remain on during this time for the system to function properly. Weekend use will not harm the system as long as the blower is on. Should seasonal use require a complete shut down of the property, then it is recommended that the blower be turned off. It is important to start up the system in advance of actual occupancy to allow for normal treatment to resume. Please contact your authorized Fusion® maintenance provider for further information concerning shut down and startup of the Fusion®. You may also contact your maintenance provider for the shut down and startup services.

HARMFUL SUBSTANCES

The Fusion® is designed to treat household type waste and can treat most common substances introduced into the system. However, certain harmful substances may reduce the efficiency or stop the treatment process by reducing or destroying the beneficial bacterial populations responsible for treatment. In general, if a chemical substance is considered harmful to humans then it should also be considered harmful to the Fusion® treatment system. If you have any questions concerning the use of any of these substances, please contact your Fusion® maintenance provider. **The introduction of any substance on the "Do Not" List into the Fusion® will void the warranty.**

- THE "DO NOT" LIST -

DO NOT introduce the following substances into the Fusion® treatment system:

- | | |
|---|--------------------------------------|
| • Motor oil | • Antifreeze |
| • Brake fluid | • Paint |
| • Paint thinner | • Gasoline |
| • Solvents | • Pesticides |
| • Herbicides | • Strong disinfectants |
| • Strong caustic drain cleaners in excess | • Toilet tank disinfection chemicals |
| • Excess pharmaceuticals | • Chemicals & chemical waste |

Not Recommended: Trash and excess food products will likely increase frequency of pumping.

Trash

- | | |
|--|---------------------------|
| • Sanitary napkins and feminine products | • Condoms |
| • Diapers | • Cat litter |
| • Paper products such as paper towels & baby wipes | • Dental floss |
| | • Cigarette butts |
| | • Plastic/rubber products |

Food Products

- | | |
|------------------------------|--------------------|
| • Coffee filters and grounds | • Greases or lards |
| • Fruit and vegetable peels | • Seeds |
| • Meat products | • Bones |
| • Garbage disposal waste | • Egg shells |

Limited Use Products

Certain products in small or moderate amounts should not disrupt the Fusion® treatment process. You should always use the minimum quantities of these substances as recommended by the manufacturer.

- Liquid laundry bleach only as needed per load
- Liquid laundry detergents without added bleach
- Liquid dishwashing detergents
- Household cleaners

EFFLUENT QUALITY

Fusion® Series systems are compact, efficient, and designed to be installed in a typical residential/light commercial environment. The final effluent leaving the system will typically be treated to the secondary quality strength of *9 mg/L CBOD₅ and 9 mg/L TSS.

*Based on NSF/ANSI Standard 40 testing.

WATER SOFTENERS

If water softeners are present in the home, Clarus Fusion® recommends the use of water and salt conservative models that are installed and operated correctly. If you have questions about softeners, contact the Water Quality Association at www.wqa.org. Contact factory for installation details.

INITIAL SERVICE POLICY

The Fusion® models ZF-450 and ZF-800 (NSF Standard 40, Class 1 certified systems) have a two-year service policy included in the initial purchase price. The service policy will include two inspections per year for a total of four inspections. During these inspections, numerous system checks and adjustments will be made to ensure proper operation.

EXTENDED MAINTENANCE POLICY

An extended maintenance policy is available for purchase from your authorized Fusion® distributor. The extended maintenance policy will include the same system checks, schedule, and adjustments as the initial maintenance policy. Please contact your Fusion® distributor or maintenance provider for further information regarding the extended maintenance policy.

AUTHORIZED MAINTENANCE PROVIDER

Your authorized maintenance provider will perform many system checks and adjustments as needed during the maintenance inspection. Two inspections per year will be made for a total of four inspections during the initial service policy. Please see the Operation and Maintenance section of this manual for further details.

Should there be any operational deficiencies with your Fusion®, the maintenance provider will notify the owner in writing when the deficiencies will be corrected. If the maintenance provider does not correct the deficiencies or the service calls are not completed, please contact Clarus Fusion® at 1-800 928 2731.

INSPECTION AND MAINTENANCE FREQUENCY

Fusion® Series systems are to be inspected and maintained every six months under normal usage. The inspection and maintenance are only to be performed by personnel trained and authorized by Clarus Fusion®. A Maintenance & Service Report (CL0059) is to be completed for each inspection and maintenance visit.

ALARM CONDITION

If an alarm condition occurs, please check the air intake area around the blower and make sure no debris blocks the blower intake. Remove the air filter cap by removing the screw from the cap and then pulling on the sides of the top of the blower. Remove the foam filter and gently tap against your other hand. If it is very clogged wash it in warm, soapy water and dry well before replacing. Reassemble filter and cap on top of blower. Do not attempt to remove the blower housing or any other parts from the blower. If the blower is operating properly, there may be a high water condition within the Fusion®. It may be necessary to discontinue water use until the alarm condition has been resolved. If the buzzer continues to sound or the red light stays on, please contact your authorized Fusion® maintenance provider. The buzzer may be silenced by toggling the black switch on the side of the alarm panel to "silence". The red beacon light will remain on until the problem has been resolved.

POWER OUTAGE

Should you experience a power outage, the blower will not operate and air (oxygen) will not be supplied to the Fusion®. If the blower is off for more than 24 hours, the lack of fresh air will cause the treatment efficiency to decrease. During a power outage, the Fusion® will still allow effluent to flow, and will not create a backup in the home. You may, however, have a pump or dose tank with a pump on the outlet of the Fusion®, which requires power to pump the effluent to the soil absorption field. If you have a system such as this, please be aware of this condition and conserve water accordingly.

EXCAVATION AND INSTALLATION

- Excavate an area large enough for the Fusion® Series unit to be installed. See Figure 8 and Table 3 for the actual dimensions of the unit. Excavation dimensions are calculated by adding 12-18" (305-457 mm) to the length and width of the Fusion®. This will allow sufficient room for proper backfilling.
- Construct a 6" (152 mm) thick stone pad of either 1/4" - 1/2" (6-13 mm) diameter stone or concrete pad and level to within 1/8" (3 mm).
- ▲ NOTICE** If the unit is not level, it will cause uneven water flow as well as unbalanced aeration, which will result in poor performance.
- Gently lift the unit at all four lifting points with a harness and install it on leveled stone pad (Figure 9).
- Check unit to make certain it is level by placing a level at several locations on the riser. (riser covers removed) (Figure 9).
- If the Fusion Unit will be installed at grade, please contact the factory for design assistance.

BACKFILLING

- If groundwater is present, anti-flotation measures must be used to stabilize the unit prior to backfilling. Please follow the procedures in the Anti-flotation section to properly anchor the Fusion®.
- Fill the unit with clean water to the normal operating depth prior to backfilling. Partition walls between chambers are water-tight and will fill in succession beginning on the inlet side of the unit. Therefore, it is best to alternate chambers when filling with water so the unit remains level. Check for leakage around the unit.
- If necessary, install riser extensions on the adapter rings prior to backfilling. See Table 1 for number and size of access openings. Riser extensions are available for deeper burial. Make certain risers are sealed properly and watertight.
- ▲ CAUTION** Apply two beads of silicone fully around each riser section prior to securing with supplied screws.
- Install riser covers.
- Backfill with good quality granular soil around the unit that is free of organic matter, rock, stone, tree roots, or other debris that could damage the unit.
- Tamp soil around perimeter of the unit as it is backfilled to stabilize the unit and to reduce settling.
- Finalize backfill with a mounded contour so that surface water is shed away from the unit. Under no circumstances should surface water be allowed to accumulate around unit.
- ▲ CAUTION** **MAXIMUM** soil burial depth over the unit is **36 inches (914 mm)**.

Table 1

| NUMBER AND SIZE OF ACCESS OPENINGS IN FUSION® SERIES | | |
|--|--------|--------|
| | ZF-450 | ZF-800 |
| 20" (51 CM) DIAMETER | 0 | 1 |
| 24" (61 CM) DIAMETER | 2 | 2 |

COLD WEATHER INSTALLATION

When installing Fusion® in cold climates, the designer may specify insulated lids and risers. In addition, the blower must be protected from snow drifts. If installed in a riser, the blower must be protected from inundation and may have a vent pipe installed to above the maximum snow depth with a 180 degree angle at the end to prevent snow and water entry. Also, the top and sides of the Fusion® may be insulated with insulation sheeting or other means to provide a minimum insulation value of R-8. Please contact the factory for further information.

ANTI-FLOTATION PROCEDURES

It is necessary to anchor the Fusion® in high ground water conditions to prevent flotation. If groundwater rises above the rock or concrete pad that the Fusion® sits on, anchoring is required. Please consult a design engineer, soil scientist or other qualified individual to determine high groundwater conditions.

- Follow the procedures outlined in the Excavation and Installation Section, items 1-5, to properly prepare and level the Fusion® excavation.
- Follow the procedures outlined in the Backfilling Section, items 1-4 to properly fill the Fusion® with water and add risers if needed.
- Refer to Figure 10, Anchoring Schematic to determine the minimum amount of backfill to be placed around the Fusion® in the excavation. Tamp the fill to prevent settling.
- Refer to Table 3, Concrete Anchoring Dimensions, to determine the amount of concrete needed for the concrete anchor collar that is poured around the entire circumference of the Fusion®. Pour concrete to the specified dimensions to fully engage the mid-seam of the Fusion®, which will anchor it once the concrete cures. Make certain to pour the concrete in a manner to minimize trapped air within the concrete. Agitating or lightly mixing the concrete with a metal rod or other similar device once poured will help release trapped air.
- Allow the concrete to harden before final backfilling.
- Complete the procedures outlined in the Backfilling Section, items 5-8.

Table 2

| FUSION® DIMENSIONS | | | | | |
|--------------------|---------------|---------------|---------------|---------------|----------------|
| SYSTEM | L | W | H | I | E |
| Fusion® 450 | 7'-1" (2.2 m) | 3'-8" (1.1 m) | 5'-2" (1.6 m) | 4'-4" (1.3 m) | 3'-10" (1.2 m) |
| Fusion® 800 | 8'-3" (2.5 m) | 4'-8" (1.4 m) | 6'-2" (1.9 m) | 5'-4" (1.6 m) | 4'-10" (1.5 m) |

Figure 8 - Dimensions

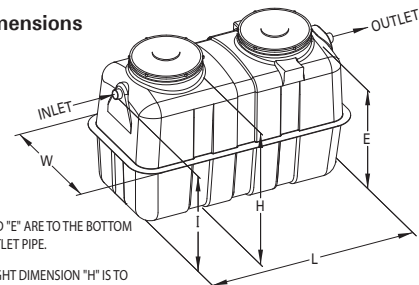

NOTES:

- DIMENSIONS "I" AND "E" ARE TO THE BOTTOM OF THE INLET/OUTLET PIPE.
- THE OVERALL HEIGHT DIMENSION "H" IS TO THE TOP OF THE NARROW ADAPTER RING. NOT THE RISER LID.
- A RISER COVER COMES STANDARD. ADDITIONAL RISERS ARE PURCHASED SEPARATELY.

Figure 9 - Lifting & Positioning

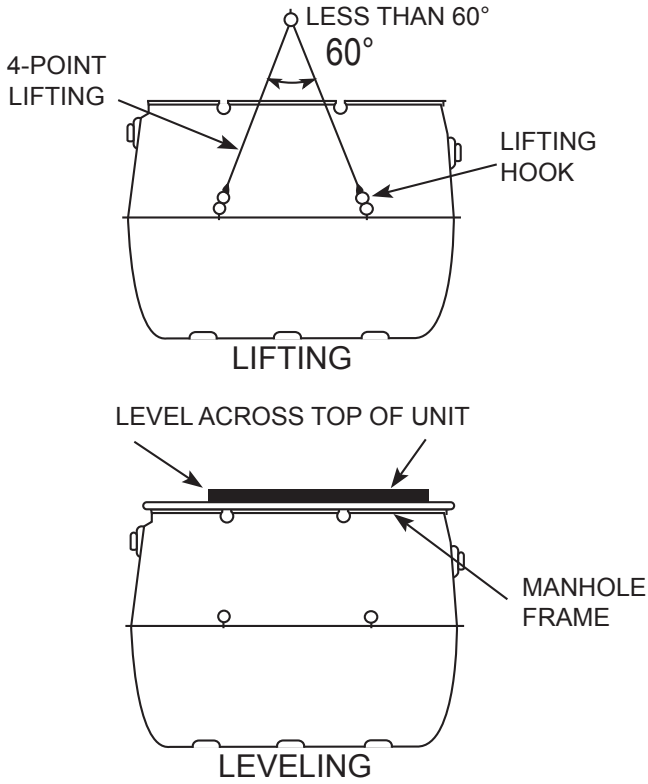
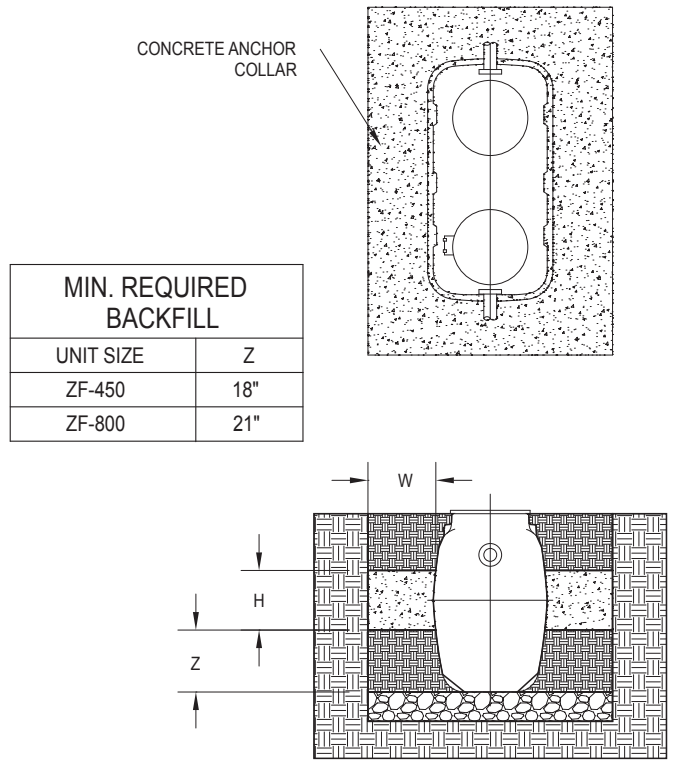

Figure 10 - Concrete Anchoring



sk2931

Table 3 - Concrete Anchoring Dimensions

| MODEL | No COVER | | | | 6" (15 cm) COVER | | | | 12" (30 cm) COVER | | | | 18" (46 cm) COVER | | | |
|--------|--------------|--------------|---|---|------------------|--------------|---|---|-------------------|--------------|---|---|-------------------|--------------|---|---|
| | W IN (CM) | H IN (CM) | CONCRETE VOLUME FT ³ (M ³) (CY) | | W IN (CM) | H IN (CM) | CONCRETE VOLUME FT ³ (M ³) (CY) | | W IN (CM) | H IN (CM) | CONCRETE VOLUME FT ³ (M ³) (CY) | | W IN (CM) | H IN (CM) | CONCRETE VOLUME FT ³ (M ³) (CY) | |
| ZF-450 | 16 (40.6) | 24 (61.0) | 72 (2.0) | 3 | 14 (40.6) | 24 (61.0) | 62 (1.8) | 3 | 13 (33.0) | 24 (61.0) | 56 (1.6) | 3 | 12 (30.5) | 24 (61.0) | 51 (1.4) | 2 |
| ZF-800 | 20 (50.8) | 24 (61.0) | 109 (3.1) | 4 | 19 (48.3) | 24 (61.0) | 102 (2.9) | 4 | 40,6 (17) | 24 (61.0) | 90 (2.5) | 4 | 16 (40.6) | 24 (61.0) | 84 (2.4) | 4 |

| MODEL | 24" (61 cm) COVER | | | | 30" (76 cm) COVER | | | | 36" (91 cm) COVER | | | |
|--------|-------------------|--------------|---|---|-------------------|--------------|---|---|-------------------|--------------|---|---|
| | W IN (CM) | H IN (CM) | CONCRETE VOLUME FT ³ (M ³) (CY) | | W IN (CM) | H IN (CM) | CONCRETE VOLUME FT ³ (M ³) (CY) | | W IN (CM) | H IN (CM) | CONCRETE VOLUME FT ³ (M ³) (CY) | |
| ZF-450 | 12 (30.5) | 24 (61.0) | 72 (2.0) | 3 | 12 (30.5) | 24 (61.0) | 51 (1.4) | 2 | 12 (30.5) | 24 (61.0) | 51 (1.4) | 2 |
| ZF-800 | 12 (30.5) | 24 (61.0) | 109 (3.1) | 4 | 14 (35.6) | 24 (61.0) | 72 (2.0) | 3 | 13 (33.0) | 24 (61.0) | 66 (1.9) | 3 |

Figure 11 - Typical Fusion® Layout

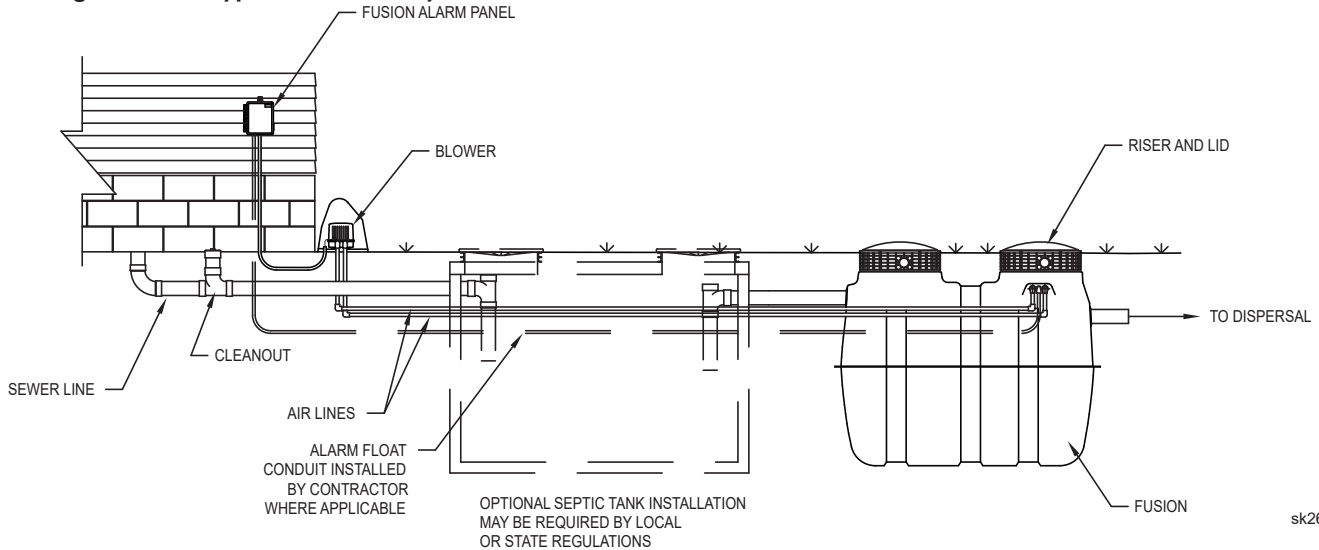

BLOWER INSTALLATION AND PLACEMENT

1. The blower does not need to be connected to a grounded, metallic, permanent wiring system, or an equipment-grounding terminal because it is double insulated, which provides grounding.
2. Place the blower where it is easily accessible for maintenance and inspection.
3. Install the blower in an area where it will be protected from damage and inundation. Also make certain the location has good ventilation.
4. Install the blower on a foundation that is level and solid.
5. Excavate trenches for two air lines from blower to the Fusion®.
6. Install two separate 1/2" (13 mm) air lines from the blower to the unit. Length of piping must be less than 17' (5 m). If distances from 17' (5 m) to 33' (10 m) are required, use 3/4" (19 mm) diameter piping (Figure 12). If longer air lines are needed, consult the factory.
7. The blower is provided with two discharge ports. The blower label is color-coded with the aeration outlet port being BLUE and the backwash outlet port being RED (Figure 12).
8. The air port inlets on the Fusion® are also color-coded, BLUE for aeration and RED for backwash (Figure 12).
9. Attach the barbed end of each PVC tee (included in the blower box) to the blower using the rubber elbows (Figure 12).
10. Attach the small diameter black air tubing (included in the blower box) to barbed fitting on PVC tee. Black air tubing and blower power cord should be routed to the alarm panel through conduit. Attach the two black air tubing lines to the two air pressure sensor barbed fittings in the alarm panel (Figure 12).
11. Connect the remaining end of each PVC tee to the airlines installed in Step 6.
12. Install the Fusion® blower at an elevation where the air line outlets are located above the elevation of the Fusion® air line inlets (Figure 12).

Figure 12

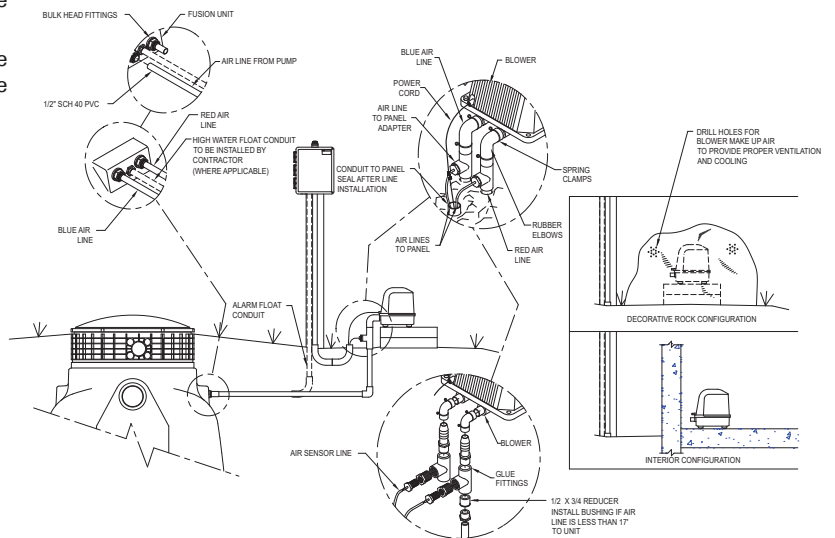

WARNING

TO PREVENT ELECTRICAL SHOCK FROM BACK-SIPHONING, LOCATE THE BLOWER ABOVE THE WATER LEVEL.

PIPING INSTALLATION

1. Connect house sewer pipe or septic tank outlet, if required, to the unit inlet. Make certain only household waste enters the unit (no foundation drains, gutter drains, floor drains, etc.).
2. Connect the outlet pipe to the outlet of the unit.

HIGH WATER ALARM FLOAT INSTALLATION

The Fusion® alarm panel assembly includes a high water alarm float switch that is used to monitor the liquid level in the Fusion® unit. The switch should be tethered to one of the gray, vertical air lines in the aeration chamber with a 3" (76 mm) tether length. The cord should pass through the opening in the partition wall between the aeration and anaerobic chamber and allow the float to hang in the outlet baffle of the anaerobic chamber.

1. The float switch should be tethered to one of the gray, vertical pipes in the aeration chamber. When the float is in the horizontal position, the cord should be at least 1" (25 mm) below the top of the partition wall opening in the anaerobic chamber baffle.
2. Place the cord into the clamp and secure to gray aeration pipe. NOTE: Do not install the cord under the clamp.
3. Position the float with a 3" (76 mm) tether.
4. Tighten the clamp with a screwdriver. Be careful not to overtighten as this may cause damage to the plastic clamp.
5. Make sure the float cord is not allowed to touch the excess clamp band during operation as this may cause damage to the cord.
6. The float switch cord should be installed in an electrical conduit connecting the alarm panel to the Fusion® unit. The electrical conduit must be rated for burial, and should be properly sealed to prevent gases from entering the alarm panel.
7. A 1/2" (13 mm) bulkhead fitting (supplied by others) should be used to connect the electrical conduit to the Fusion® unit. A hole must be drilled through the wall of the Fusion® unit between the red and blue bulkhead fittings to facilitate this connection.
8. Please be certain that the bulkhead fitting for the electrical conduit forms a watertight connection with the FRP wall of the Fusion® unit.
9. Electrical conduit from the Fusion® unit to the alarm panel can be buried in the same trench as the air lines.
10. The control switch can be wired directly into the alarm panel. See Figure 7.

ELECTRICAL CONNECTIONS

1. **▲ NOTICE** All electrical installations must follow the National Electrical Code and/or your local/state electrical codes.
2. The blower should be directly wired into the alarm panel. The blower's power cord does not contain a ground wire because it is internally grounded with double insulation. The alarm panel must be located in a dry location that is accessible for maintenance. Please see Figure 7 and the wiring diagram and instructions enclosed with the alarm panel.
3. Make certain the timer within the control panel is set to the proper time. The timer unit display should be set to 10 hrs. and the timer dial needle set to 3.6 for 36 hours. This will activate an alarm if the blower doesn't go into backwash cycle within a 36-hour time frame.

START UP

▲ NOTICE An installation and start-up check list (CL0057) is furnished with the information package in the blower box. Please use this as a guide and fill out all sections and return to your distributor.

Figure 13 - Aeration Flow Adjustment

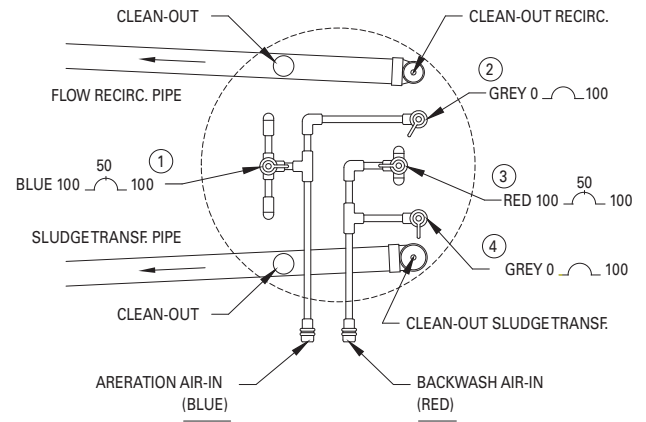

SK3208

Valve Legend:

| | | | |
|------------------|------|--------------------|------|
| 1. Aeration | Blue | 3. Backwash | Red |
| 2. Recirculation | Gray | 4. Sludge transfer | Gray |

There are two aeration systems provided within the aeration chamber: normal aeration and backwash. Valves (1 and 3) are set at 50%. Observe the air flow on each side of the unit to verify equal flow. If there is an obvious discrepancy in air flow between the two sides, adjust the valves (1 and 3) so that the flow is equal.

RECIRCULATION FLOW ADJUSTMENT

The recirculation flow is designed to be 1.2-1.8 times that of the average design inflow. Table 4 indicates starting flow rates for each unit. However, fine adjustments may be necessary to ensure optimum performance.

Setting the flow rate:

- Adjust the flow using rates in Table 4.
- The flow rate is adjusted by rotating the gray recirculation valve (2) and observing the flow at the pipe end.
- There are prescribed lines at the outlet of the recirculation pipe to aid in approximating the correct flow.

Measuring the flow rate:

- The actual flow rates must be measured to verify flow after adjustment of the valve and observation at the pipe end.
- Measure the time in seconds required to fill a 1L container.
- Compare the time to value ranges in Table 4.
- If necessary, adjust the valve again and collect another sample to verify the correct flow rates.

▲ NOTICE It is important not to set the flow rate too high because it can cause excessive agitation within the first chamber (Sedimentation Chamber). This could result in poor performance.

Table 4 - Recirculation Flow Rates

| Model | ZF450 | ZF800 |
|-------------------------------------|--------|--------|
| Recirculating flow rate (sec/liter) | 29-45 | 14-22 |
| Suggested Valve Opening | 35-40% | 30-35% |

Figure 14 - Flow Measurement

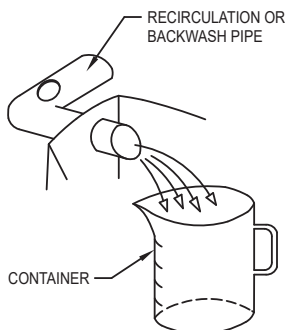

SK3195

BACKWASH FLOW ADJUSTMENT

In order to prevent plugging of the media in the aeration chamber, the backwash cycle activates at a preset schedule. If there is no backwash cycle or if the backwash cycle is too short, the unit's performance will be adversely affected. Likewise, if the backwash cycle is too long, performance will be compromised.

The backwash cycle begins at 2:00 AM and lasts for five minutes. One hour later, another five minute backwash cycle occurs. The backwash initiation time can be set for any time during a 24-hour period to accommodate unusual water use patterns. The goal is to set the time when there is no flow into the unit.

The backwash cycle and sludge transfer from the aeration chamber takes place in the same action. Verify that the air flow is uniform across the aeration chamber during a backwash cycle. If not, adjust the red backwash valve (3) accordingly.

Setting the flow rate:

- On all HIBLOW HP series model blowers, press the [MINUTE] button for at least 2 seconds to switch to manual mode. The "aeration" and "backwash" can be switched by the [MINUTE] button.
- Set the backwash flow rate by adjusting the gray sludge transfer valve (4). Use Table 5 to determine the setting for each Fusion® model.

Measuring the flow rate:

- Measure the actual backwash flow rate at the outlet of the sludge return pipe in the first chamber the same way the recirculation flow rate is measured.
- Adjust the gray sludge transfer valve (4) if necessary to obtain the proper flow.
- Be sure to press [SET] to return the unit back to auto mode on HIBLOW Unit.

Table 5 - Backwash Flow Rate Setting

| Model | Frequency | ZF450 | ZF800 |
|--------------------------------|-----------|--------|--------|
| Backwash flow rate (sec/liter) | Twice/day | 7-10 | 4-6 |
| Valve open (%) | Twice/day | 50-55% | 40-45% |

Figure 15 - Flow Controlling Valve

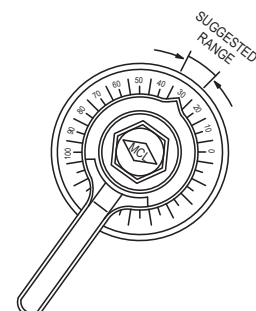

SK3195

HIBLOW DU080 BLOWER TIMER SETTING

Figure 16



HIBLOW Blower

HiBlow Timer Settings

To Adjust Clock:

1. Remove phillips screw from top of upper housing and then detach filter cover to access LCD screen from the back of housing.
2. Press Select button ● twice and shift to Set mode.
3. Press Edit buttons ↑ plus ↓ simultaneously and shift to adjust clock.
4. Press Up button ↑ or Down button ↓ then select AM or PM. Press Select button ● and shift to hour setting
5. Press Up button ↑ or Down button ↓ then set hour. Press Select button ● and shift to "min" setting.
6. Press Up button ↑ or down button ↓ then set "min". Hold Select button ● for 1 second to set time.

Backwash Cycles:

1. Port two is used for main aeration cycle and port 1 is used for the backwash cycle.
2. The blower is factory preprogrammed with the correct frequency and duration of backwash cycles per day. The first backwash cycle is set to begin at 2:00 AM and end at 2:05 AM. The second backwash cycle is set to begin at 3:00 AM and end at 3:05 AM. Please follow steps 1-5 below to verify the correct settings or to adjust/change them.

To Adjust/Change Backwash Settings:

1. Press Select button ● twice and shift to Set mode.
2. Press Up button ↑ three times until "ID 03" is showing.
3. Press Edit buttons ↑ plus ↓ simultaneously.
4. Follow set/change clock instructions to change the start time.
5. Enter end time and hold Enter button ● for 1 second to complete.

To Switch Between "Manual" Backwash Mode and "Auto" Backwash Mode:

1. Press Select button ● once and shift to manual mode.
2. Press Up button ↑ or Down button ↓ to change ports.
3. Press Select button ● two times to shift back to AUTO mode.

FUSION® OPERATION AND MAINTENANCE

The following steps are to be completed during each 6-month inspection. All information collected during the inspection is to be recorded on the Maintenance and Service Report (CL0059). Begin the inspection by recording the date, arrival time, weather conditions, purpose of the visit, water use, model number, serial number, the presence or absence of a septic tank, and the system owner and service provider information in the space provided on the report.

GENERAL OBSERVATIONS

1. **Are any odors present?** There should be no odor with the lids closed, if properly sealed. With lids removed, a septic or sewer-like odor is indicative of poor treatment and is common immediately after startup due to hydrogen sulfide and other gases. A well-operating system will have a musty, earthy smell similar to wet peat moss.
2. **Is there evidence of high water?** Typically indicated by a water level above the black wall markings and above the "0" graduation on the partition wall stickers. May also be indicated by debris on partition walls.
3. **Is there excess foam formation?** Foam may be present during an inspection. Brown foam indicates bacterial buildup following startup. White foam is due to detergent use. Neither is a problem if occurring intermittently. Detergent-based foam will often be accompanied by low transparency readings.
4. **Is there residue build-up on piping?** Typically indicated by gray or black residue (dried foam) on aeration chamber piping.
5. **Is there even and vigorous bubbling?** Bubbles surfacing in the aeration chamber should be even across the entire chamber. If uneven, cleaning steps should resolve this issue.

REQUIRED WATER QUALITY ANALYSES

PART A: Clean Water Storage Chamber – Collect samples from the clean water storage chamber to be used for the following analyses

1. **Transparency** – Measures the ability of the water to transmit light. Using the ladle, fill the transparency tube with a water sample collected from the clean water storage chamber. Looking down through the water column, slowly drain the transparency tube using the valve on the flexible hose until you can first distinguish between the black and white colors on the secchi disk in the bottom of the tube. When the secchi disk is visible, close the valve and read the transparency (in centimeters) on the side. Dirty water samples transmit less light and result in a lower transparency. A transparency reading > 20 cm is preferred and 34 cm is average. Low transparency may be due to a lack of biological activity as in a young system, a recirculation rate that is too high, or a system influent high in detergent concentration. To correct low transparency readings not caused by detergent, decrease the recirculation rate. Detergent based problems may require consultation with owner.

2. **Scum** – Very small amounts of scum may accumulate in the corners on the outlet end of the system. This is normal. Scum, should not be present elsewhere in the clean water storage chamber unless the recirculation rate is too high or daily flow exceeds the design capacity. If present, use ladle to transfer to sedimentation chamber.
3. **Sludge** – Test the sludge depth using the sampling device included in the maintenance kit. The bottom section of the sampler includes a check valve, which opens as the unit is lowered into the liquid. When the sampler has reached the bottom of the chamber and the liquid level equilibrated at surface level, lift the sampler and this action will set the check valve and retain the sample in the tubing. Withdraw the sampler and note the depth of settled solids within the sample. To release the material in the unit, touch the stem extending from the bottom section against a hard surface such as the partition wall in the sedimentation chamber. This opens the check valve to drain the sample. A range of 0" to 4" is preferred. Typically solids are brown and well flocced. More than 4" (0-102 mm) is typically due to high recirculation rates and sludge will appear black in color. To correct sludge depths greater than 4" (0-102 mm), decrease the recirculation rate and increase the backwash rate.

Sludge Descriptions:

Black – septic or sewer-like odor due to hydrogen sulfide and other gases

Brown – undigested sludge is light brown, becomes darker with digestion, lightly settled

Clear – may see a clear water layer beneath solids if gas carries solids upwards

Flocced - settled with texture similar to a tuft of wool

Grainy - gritty or sandy texture

Gray - partially digested sludge

Milky – light in color, cloudy, not transparent

Muddy – typically well settled, often present just after startup, may be due to infiltration

Mustard - an off-color, remnants of digestion are often yellowish in color

White - sometimes present after new construction often due to drywall mud

PART B: Anaerobic Chamber - collect samples from the outlet baffle of the anaerobic chamber to be used for the following analyses:

1. **Transparency** – A transparency reading more than 20 cm is preferred.
2. **Scum** – Should not be present unless recirculation and/or backwash rate is too high or daily flow exceeds design capacity. To correct, reduce the recirculation and or backwash rate.
3. **Sludge** – A range of 0" to 15" (0-38 cm) is preferred. Typically brown and settled, becomes gray to black as depth and digestion increases. More than 15" (38 cm) may require a reduction in recirculation rate. A sludge accumulation of greater than 24" (61 cm) in

FUSION® OPERATION AND MAINTENANCE, continued

the sedimentation and 15" (38 cm) in the anaerobic chamber requires pumping.

PART C: Sedimentation Chamber – collect samples from the outlet baffle of the sedimentation chamber for the following analyses:

1. **Scum** – 0" to 12" (0-30.5 cm) is common, so long as it is not rising above the partition wall. If so, punch down using ladle.
2. **Sludge** – A range of 0" to 24" (0-61 cm) is common. Typically brown and settled, becomes gray or black as depth and digestion increases. A sludge accumulation of >24" (61 cm) in the sedimentation chamber and 15" (38 cm) in the anaerobic chamber requires pumping.

Figure 17 - Inspection details

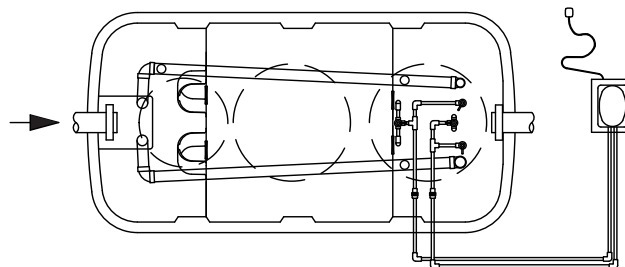
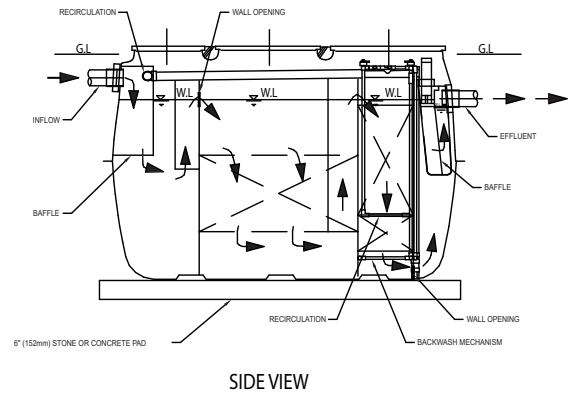
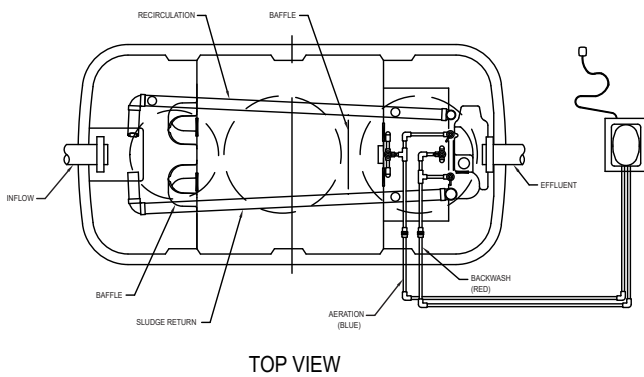

SK3194

AERATION CHAMBER CLEANING

1. Aeration

The aeration system must be flushed every maintenance visit. There are two flushing methods: (A) Air flushing and (B) Water flushing. Air flushing must be done every maintenance visit. Water flushing may be done if there is a sign of clogging in the aeration chamber (e.g. abnormal increase in recirculation flow).

Figure 18

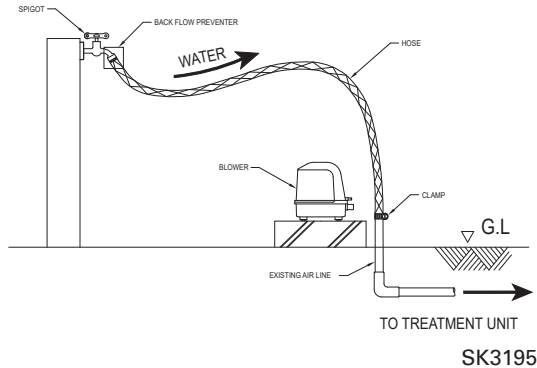

(A) Air flushing procedure:

- Make sure the blower is in the aeration mode.
- Make sure a check valve or backflow preventer is present for water flushing procedure.
- Close gray recirculation valve (2) all the way. (0%)
- Rotate blue aeration valve (1) back and forth from the 0% to the 100% position several times to flush.
- Set valves (1) and (2) back to the appropriate positions. (See Recirculation Flow Adjustment, pg. 10)

(B) Water flushing procedure: (See Figure 18)

- Make sure the blower is off.
- Close valve (2) all the way.
- Connect a water line to the aeration line as shown in Figure 18.
- Gradually open the water faucet and introduce water into the system.
- Rotate valve (1) back and forth from the 0% to the 100% position several times to flush.
- Turn off the water, remove the water line, and reconnect the air line to the blower.
- Set valves (1) and (2) back to the appropriate positions. (See Recirculation Flow Adjustment, pg. 10)

(C) Cleaning the recirculation line:

- Make sure the blower is in the aeration mode. If not, change the mode by pressing the Manual Backwash button.
- Open the gray recirculation valve (2) to 100%.
- Flush water through the recirculation line for several seconds.
- Turn off the recirculation by rotating the gray valve (2) to 0%.
- Make sure the blower is off. Allow the system to relax for a few seconds.
- Repeat this cleaning method three times.
- A hose or brush can also be used to clean the recirculation line. See Figure 20.
- Reset the gray valve (2) to its original position.

2. Backwash

The backwash system must be flushed every maintenance. There are two flushing methods: (A) Air flushing and (B) Water flushing. Air flushing must be done every maintenance visit. Water flushing must be done if there is a sign of clogging in the aeration chamber (e.g. abnormal increase in recirculation flow).

(A) Air flushing procedure:

- Make sure the blower is in the backwash mode.
- Close the gray sludge transfer valve (4) all the way.
- Rotate the red backwash valve (3) back and forth from the 0% to the 100% position several times to flush.
- Set valves (3) and (4) back to the appropriate positions. (See Backwash System)

Figure 19

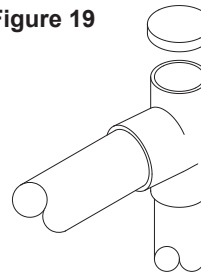

(B) Water flushing procedure:

(See Fig. 19)

- Make sure the blower is off.
- Close valve (4) all the way.
- Connect a water line to the backwash airline as shown in Figure 18.
- Gradually open the water faucet and introduce water into the system.
- Rotate valve (3) back and forth from the 0% to the 100% position several times to flush.
- Turn off the water, remove the water line, and reconnect the airline to the blower.
- Set valves (3) and (4) back to the appropriate positions. (See Backwash System)

(C) Cleaning the sludge transfer line:

- Make sure that the blower is in the backwash mode. If not change the mode by pressing Manual Backwash.
- Open the gray sludge transfer valve (4) to 100%.
- Flush water through the sludge transfer line for a few seconds.
- Repeat this cleaning method three times.
- A hose or brush can also be used to clean the sludge transfer line. See Figure 20.
- Reset the gray valve (4) to its original position.
- Return the blower to the normal aeration mode. by pressing Manual Backwash.

Figure 20

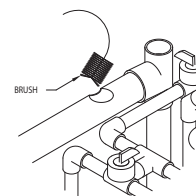

SK3195

3. Foam formation

Make sure there is not an excess amount of foam on the surface. If excessive foam is present it may indicate high detergent usage. Meet with owners to inform and educate them concerning excessive use.

4. Abnormal water level

If the water level exceeds the partition wall, clean the plastic cage first with a brush, then check for possible clogging in the filter media section. Clogs may be cleared by using a manual backwash tool. The manual backwash tool may also be used to eliminate a clog in the anaerobic chamber media as well.

FUSION® PUMPING

Wastewater entering the Fusion® contains organic and inorganic materials. If organic in nature, it is treated and decomposed by microorganisms during the treatment process. If inorganic in nature, it will be stored within the Fusion®. The stored materials accumulate as scum (floating) or sludge (solids on the bottom) and must be removed periodically to ensure the performance of the Fusion®. Please review the Operation and Maintenance sections part B and C to determine when the maximum depths of scum and sludge have been reached and pumping is required. Follow the procedures in Figures 21 and 22 to remove scum and sludge from the sedimentation and anaerobic chambers only. When finished, refill both chambers with clean water to prevent the possibility of flotation.

Figure 21 - Sedimentation Chamber Pumping

Step 1: Remove the scum.

Step 2: Remove the sludge

Step 3: Remove the sludge under the media while washing the filter with tap water.

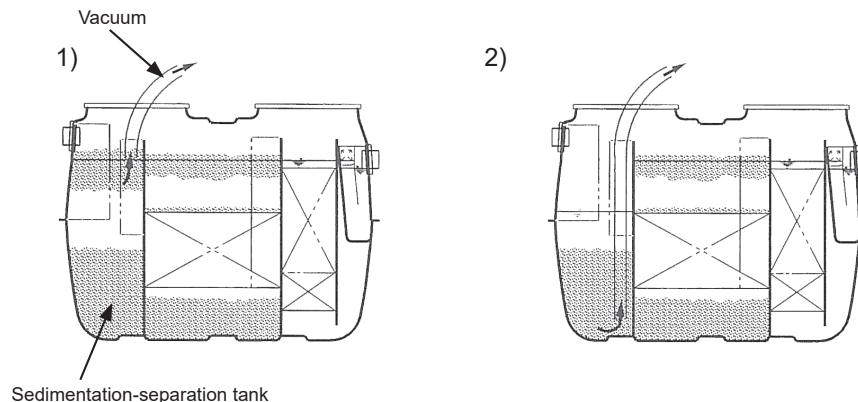
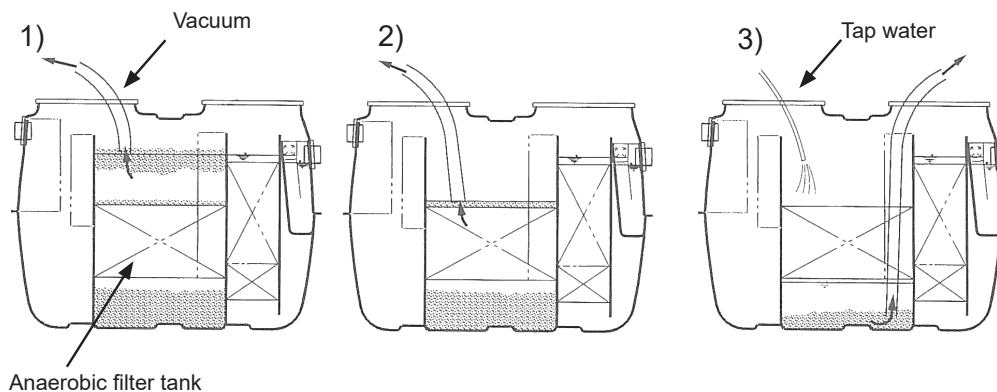

Figure 22 - Anaerobic Chamber Pumping



▲ NOTICE Remove the scum first. If you remove the sludge first, the water level will decrease and the anaerobic filter will be blocked by the scum.

ALARM PANEL & BLOWER INSPECTION AND MAINTENANCE

Inspect the alarm panel for signs of water or odors inside. Toggle the test switch on the side of the box to check that both the alarm horn and the alarm beacon light are operational.

Inspect the blower for proper operation. If the blower is not functioning, refer to the troubleshooting section near the end of this guide.

1. For the HiBlow DUO80 blower, inspect the air filter once power has been disconnected by removing the phillips screw from top of upper housing and then detach filter cover to access filter (page 17). Remove the filter and inspect it. Remove any dirt and dust or replace it with a new filter. The filter may be washed in soapy water. Make certain it is completely dry before replacing it. Remove any dust from the upper housing before reattaching the upper cover.

2. Ensure the correct time is shown on the blower's display screen, keeping in mind that the display shows a 24-hour clock (not AM/PM).
3. Engage the manual backwash cycle as instructed on page 11 and ensure the blower switches into backwash. Be sure to switch the blower back into Auto as instructed on page 11.

TROUBLESHOOTING

1. Odor

Offensive odors are often the result of insufficient or inappropriate bacterial growth. Causes may include a young or unestablished system, insufficient air introduction, or the addition of detrimental chemicals or poisons into the system. Ensure the blower and air delivery systems are functioning. Check with the owner regarding chemical use and disinfection habits. Check all risers and lids to ensure an airtight seal.

2. Foam Formation

Foam formation is observed in the following situations:

1. In the early stage of operation when the aerobic bacteria colony is establishing itself.
2. When an excess amount of air is supplied for aeration
3. When the difference between ambient temperature and water temperature is great.
4. When an excessive amount of detergent is introduced.

In most cases, foam will disappear with proper operation. When excessive amount of detergent have been introduced to the system remind the owner to use appropriate amount of detergent.

3. Cloudy Treated Water

- Check the amount of scum and sludge:
If too much scum or sludge is observed, transfer them to the first chamber and adjust recirculation flow rate as well as backwash time, frequency and duration. (See backwash flow adjustment)
- Check the aeration situation:
If uneven bubble generation is observed, adjust valve (1). If aeration is weak, flush the aeration pipe with air or water.
- Check the recirculation flow rate:
If the recirculation flow rate has increased after the last inspection, the aeration pipe may be clogged. Flush the aeration pipe with air or water. If the recirculation flow rate has decreased after the last inspection, the airlift pump or recirculation pipe may be clogged. Clean them with a brush and running water.
- Check the color of the returning sludge from the backwash pipe:
If the color is abnormally dark, decrease the recirculation flow rate accordingly. If the TSS of the water from anaerobic to aeration chamber is high, check the sludge accumulation. If the sludge accumulation reaches the upper limit, pump out the sludge. If not, backwashing the anaerobic chamber by using a manual backwash tool (figure 18) may assist.

4. Blower

Blower motor does not run, with power connected:

- Check the electric supply to the panel, ensuring 120 volt service.
- Check that all breakers and fuses in the panels are intact.
- Check the blower's safety switch mechanism (See pages 20).

Little or No aeration/ backwash air:

- Check the blower motor is running.
- Check the air line piping connections at the blower.
- Check the air filter and clean or replace if necessary.
- Check the diaphragms and replace if necessary.
- Check the air piping for leaks, clogs, or dislocations and correct accordingly.
- Verify check valves (if installed) in supply lines are installed correctly.

Blower- Manual backwash does not work.

- Manually toggle between recirculation and backwash several times, listening closely for a light click within the unit.
- If the unit clicks, but the air does not switch from aeration to back-wash, consult the factory.

CLEANING THE HIBLOW DUO 80 FILTER (Refer to Fig.23)

- Remove screw (refer to fig.23-1). Detach filter cover from upper housing (refer to fig.23-2).
- Replace with a new filter or clean the filter. Dust off filter to remove dirt and dust in case it is soiled heavily (refer to fig.23-3). (Filter can be washed with soap and water. Make sure that filter is dried before reattaching.)
- Remove the dust at upper housing (refer to fig.23-4).
- Install filter and make sure that all 8 projections stay in filter and make sure that filter is dried before reattaching.
- Attach filter cover. Insert bosses on the bottom of filter cover into flutes on upper housing (refer to fig.23-6).

Fig.23

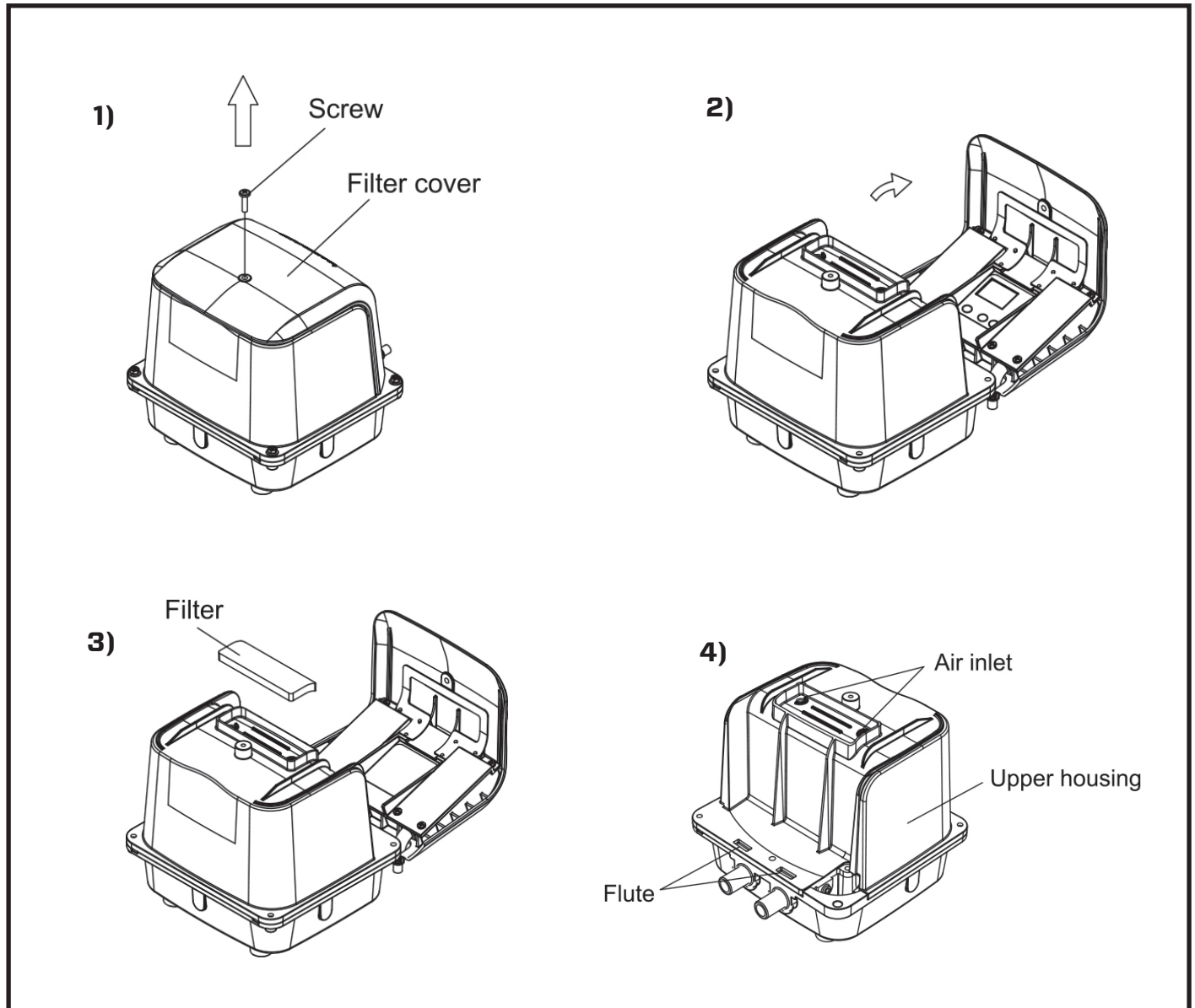

5)

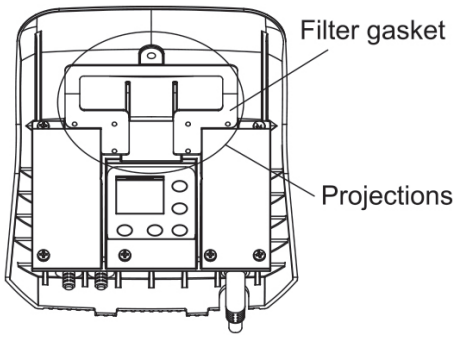

6)

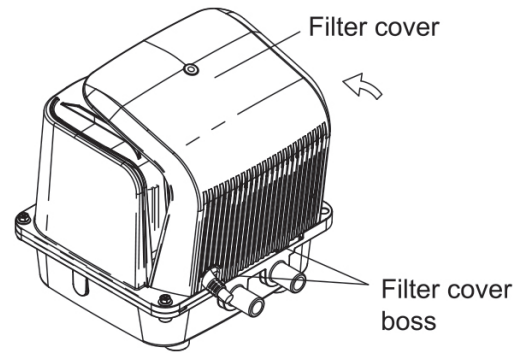

Replacing Diaphragm Blocks

[1] Replacing built-in block (Refer to Fig.24)

- Remove all 5 screws and remove upper housing (refer to fig.24-1).
If it is stuck, insert screwdriver between upper housing and lower housing to pry apart.
- Remove sound absorber (refer to fig.24-2).
- Pull connector out (refer to fig.24-3).
- Remove screw from cord clamp.
- Remove 4 cushion rubbers pads. Remove built-in part (refer to fig.24-4).

Fig.24

1)

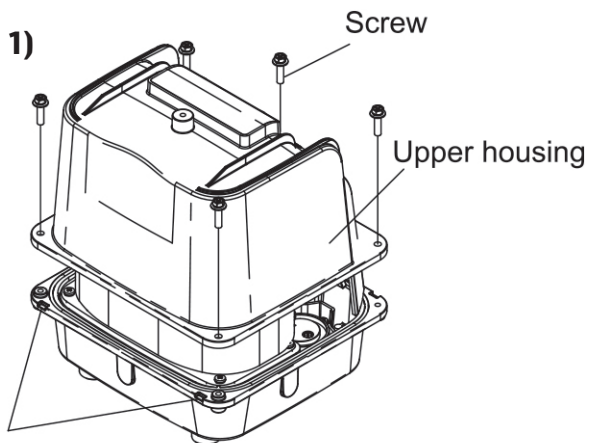

Screwdriver inserting positions

2)

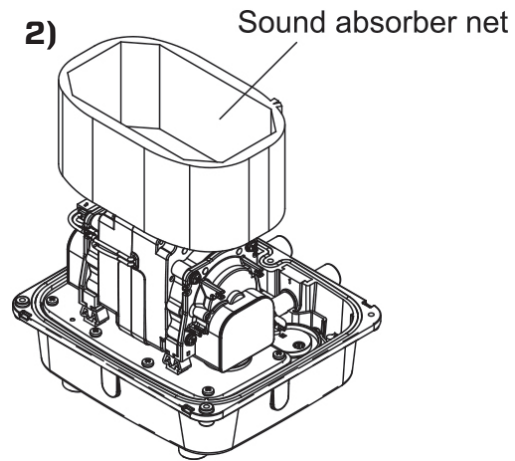

3)

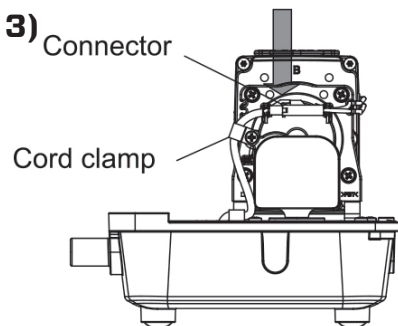

4)

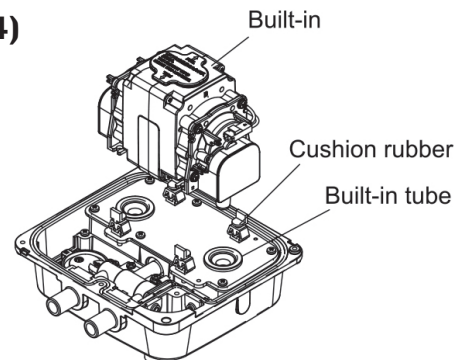

[2] Replacing chamber block (Refer to Fig.25)

- Remove built-in cover. Pick part up to remove the cover (refer to fig.25-1) .
- Insert gap jig for XP (that is attached to DUO repair kit) into one side (refer to fig.25-2).
- Remove one side of casing block. Loosen casing mounting screws and remove casing as shown in fig.25-3).

Fig.25

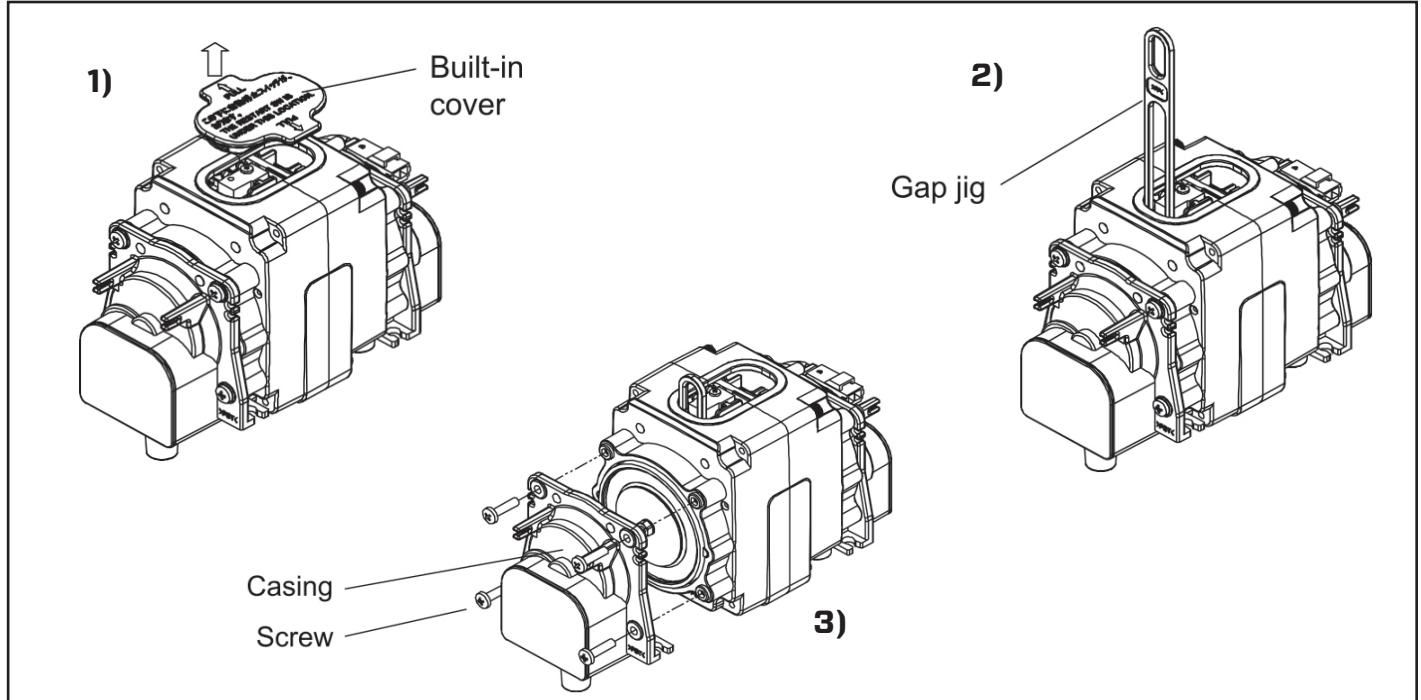

[3] Replacing Diaphragm block (Refer to Fig.26)

- Remove locknut and washer (refer to fig.26-1).
- Remove diaphragm ring and diaphragm (refer to fig.26-2). In case it is not easy to remove, pull with long nose pliers.
- Attach one side of diaphragm. As shown in fig.26-3, put shadowed area together. Insert new diaphragm into groove on frame.
- Attach diaphragm ring back together (refer to fig.26-4). Use new diaphragm ring (attached to diaphragm parts).
- Attach washer and tighten locknut as shown in fig.26-1.
- Make sure that the center plate is at the center of a diaphragm (refer to fig.26-5).
- Attach casing block. Tighten 4 casing mounting screws as shown in the fig.25-3).
- Exchange opposite diaphragm repeating the same steps.

Fig.26

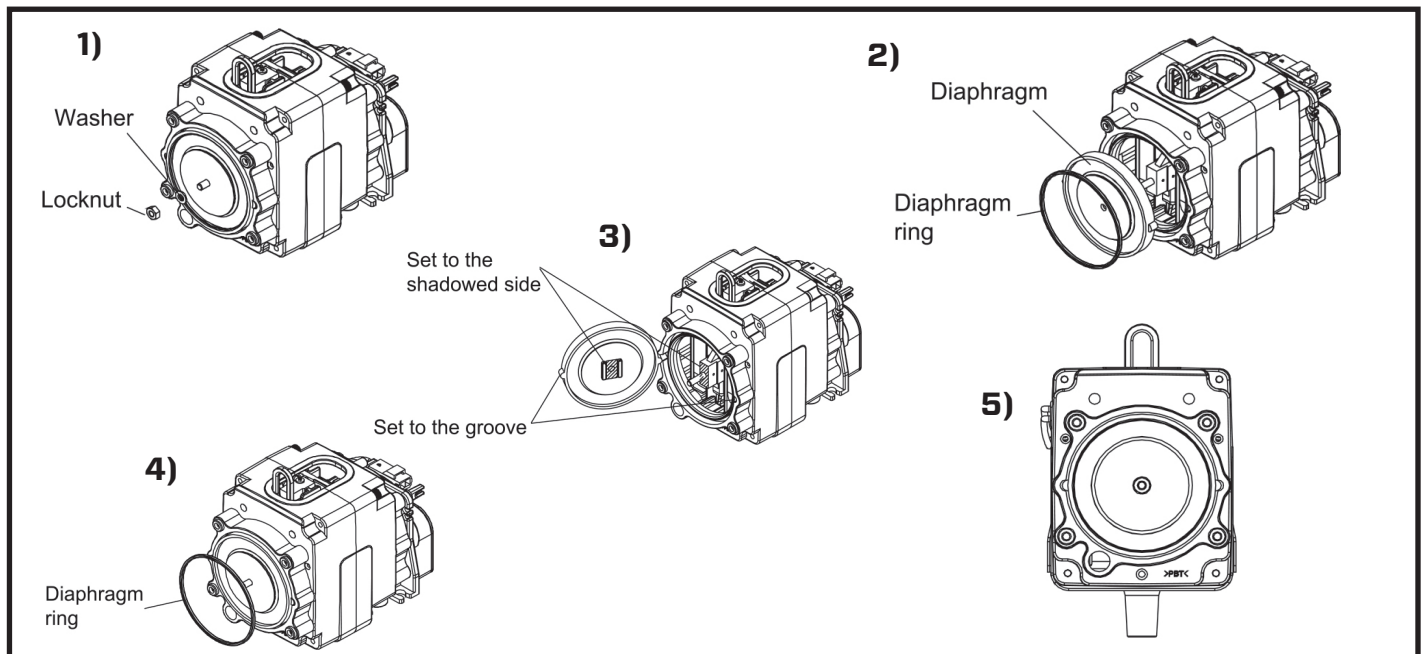

[4] Resetting Safety Switch (Refer to Fig.27)

- If safety switch has tripped, please reset for operation.

Fig.27

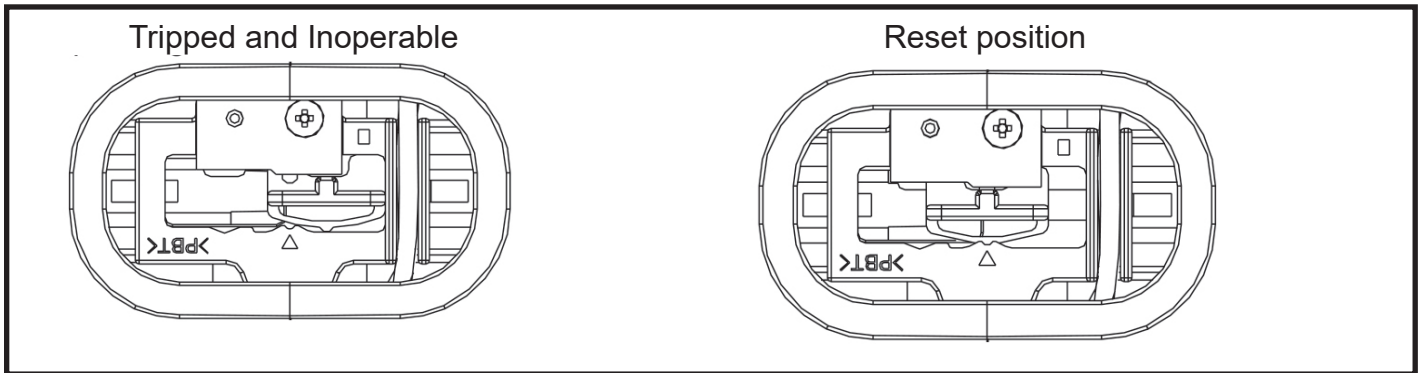

[5] Reinstalling Built-in block (Refer to Fig.28)

- Reattach built-in cover parallel to frame (refer to fig.28-1) .
- Reattach 4 cushion rubber pads to built-in part, connect power cord and terminal for built-in part. Reattach lead wire to casing as shown in fig.28-2).
- Tighten screw on cord clamp.

Fig.28

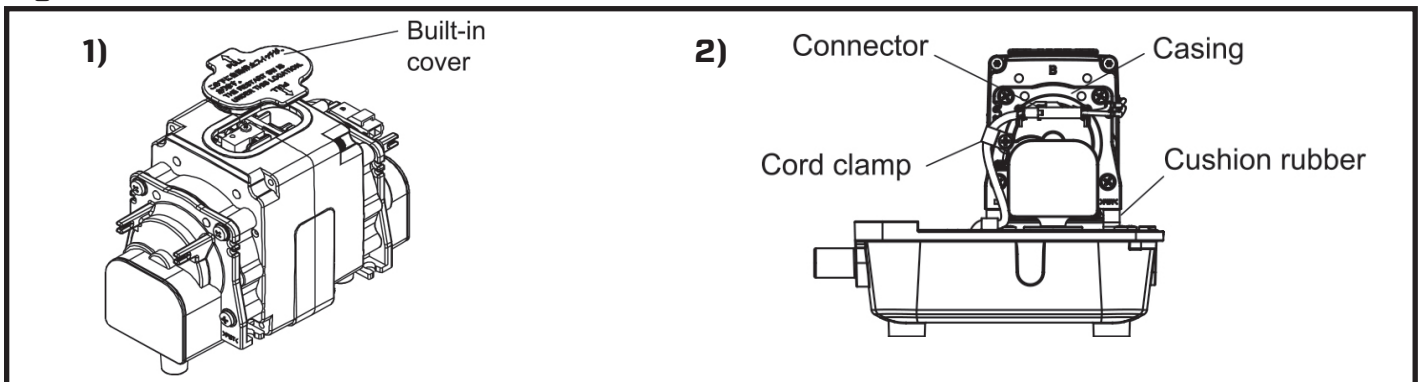

MAIL TO: P.O. BOX 16347 • Louisville, KY 40256-0347
SHIP TO: 3649 Cane Run Road • Louisville, KY 40211-1961
(502) 778-2731 • 1 (800) 928-PUMP • FAX (502) 774-3624

Trusted. Tested. Tough.®

Visit our website:
zoellerpumps.com