

THE SHARK[®]

Series

Model 840

AUTO-REVERSING GRINDER PUMP

- Hardened 440C stainless steel cutter and disc
- Cutter reverses, automatically alternates direction to extend blade life and free hang-ups (automatic or manual)
- Moisture detection probes
- 1 Phase – integral thermal overload
- 3 Phase – thermal sensor and leads
- Oil-filled, hermetically sealed motor with Class F insulation
- 1-1/4" NPT vertical discharge
- Vortex impeller: Ductile iron
- Buna-N O-rings
- Dual mechanical shaft seals with leak detection – carbon/ceramic
- Preassembled systems available
- Explosion proof models available

100% Factory Tested prior to shipment.

(Certified testing available. Consult factory representative for more information.)

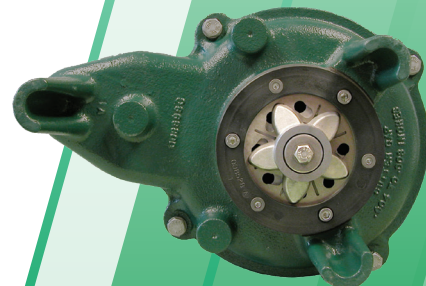

ZOELLER[®]
PUMP COMPANY

Trusted. Tested. Tough.[®]

FM3184
1019
Supersedes
New

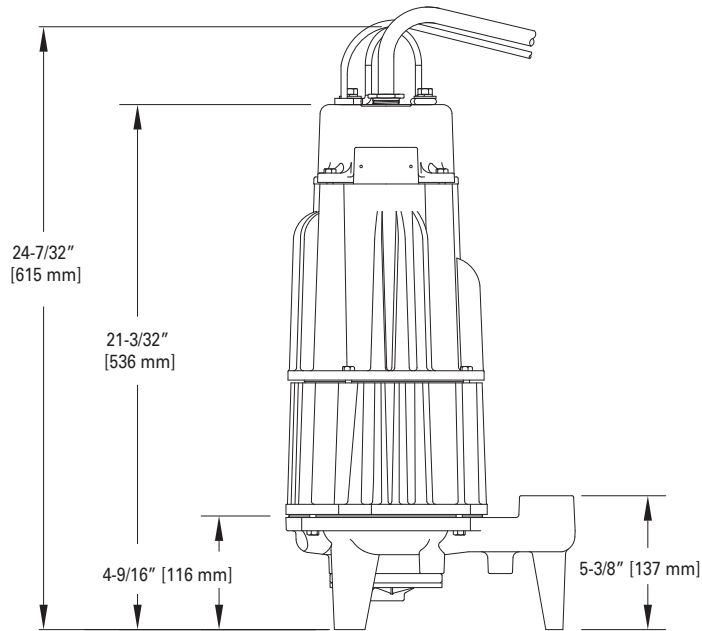

SK1322

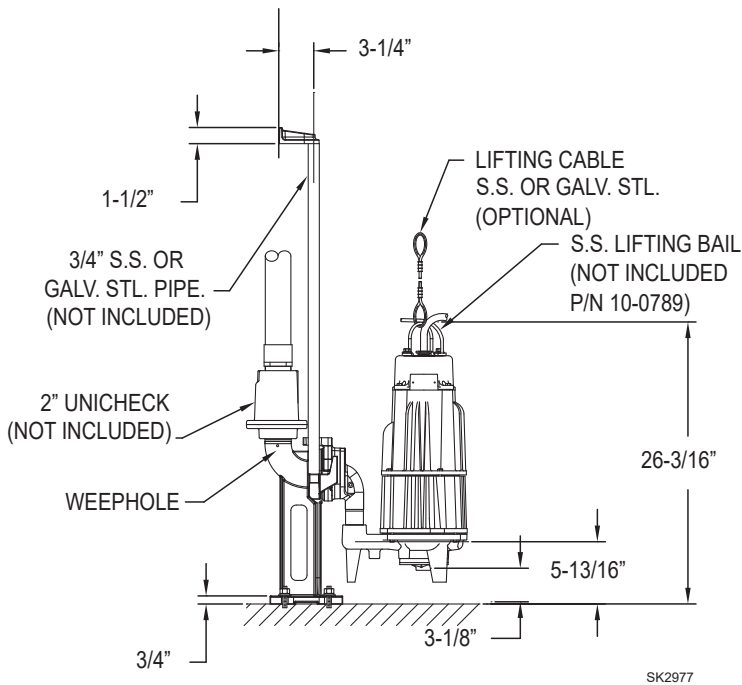

SK2977

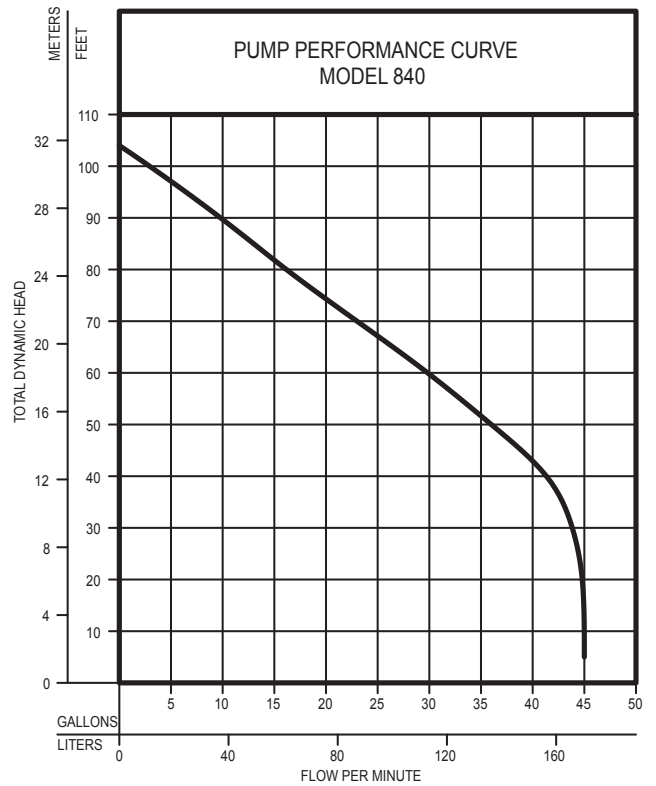

009960



Certified to CSA Standard C22.2 No. 108.

